

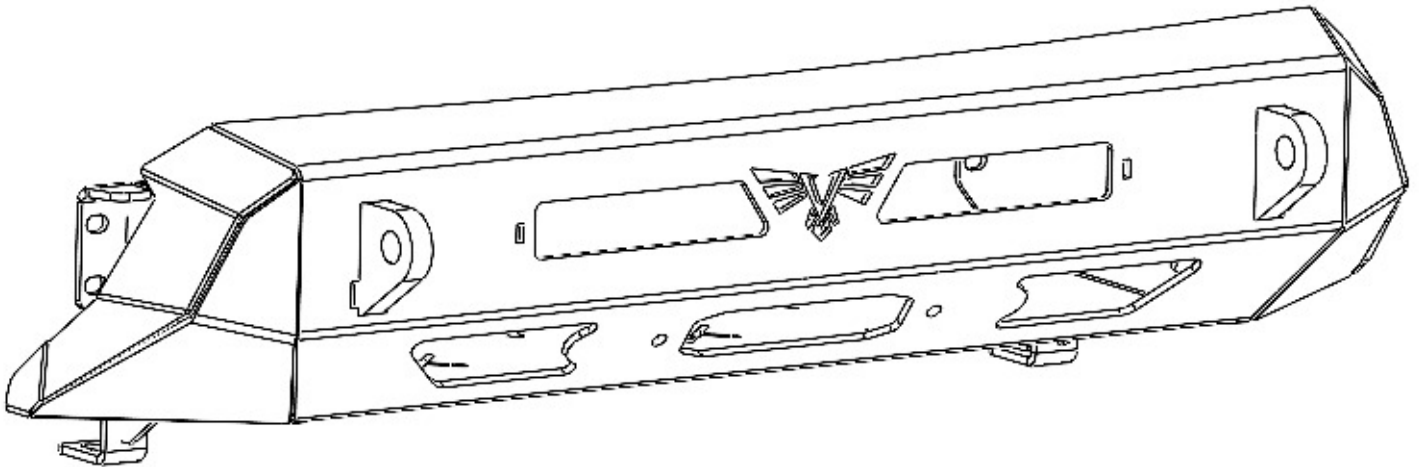

VICTORY4X4

16-23 TOYOTA TACOMA FRONT BLITZ BUMPER

INSTALL INSTRUCTIONS



**Please read the instructions below carefully before attempting to install.
2nd Gen cut will require a little more cutting and will be detailed at the end of this
document. The rest of the install will be the same. You can then start at step 4.**

Thank you for purchasing from Victory 4x4! Checkout our website, victory4x4.com for other great off-road products. Be sure to rate and review our product online. If you have any questions or are missing parts, please don't hesitate to call us at 269-459-8447!

INCLUDED HARDWARE

INCLUDED BOLT PACK(S) 046-0033

Note: Some Victory 4x4/JCR Offroad/SquatchProof products share hardware kits. Any extra hardware you may receive that is not listed below can be repurposed or discarded.

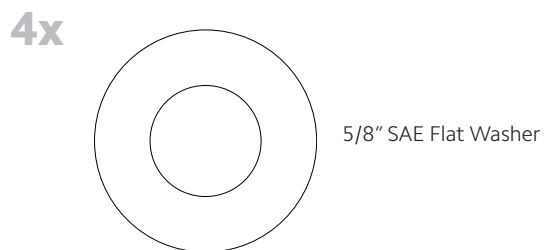
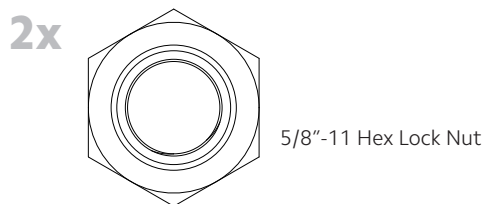
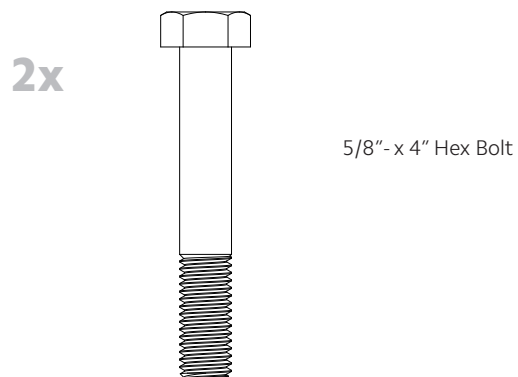
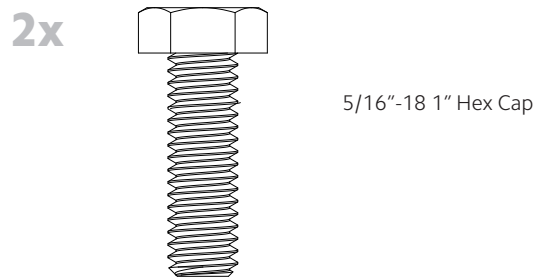
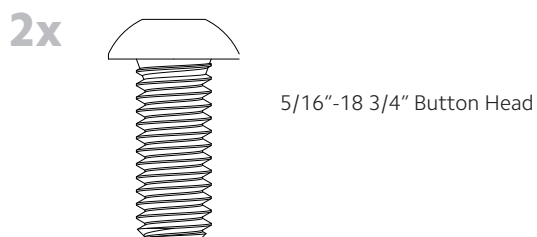
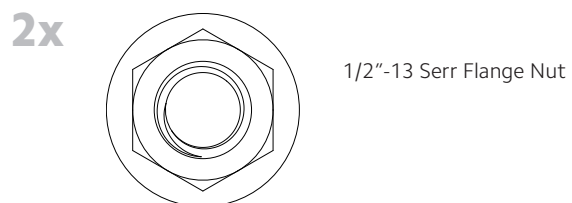
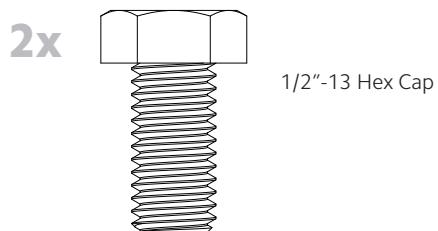

INCLUDED PARTS

2x

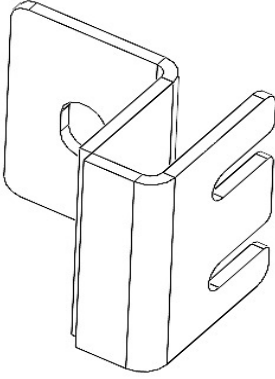

Tie-In Brackets

TOOLS NEEDED

- Body Saw
- 10mm Socket
- 14mm Socket
- 5/16" Drill Bit
- 3/16" Allen

1x

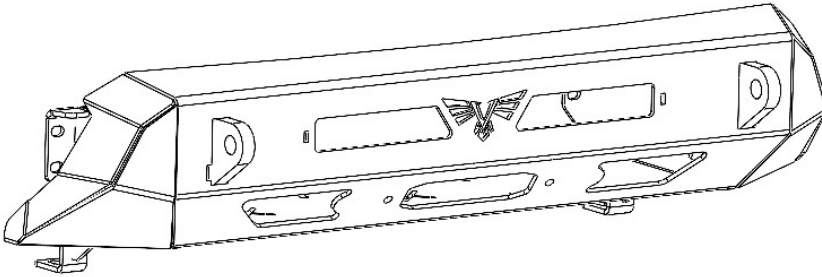

Bumper

ASSEMBLY

1. Assemble your Blitz bumper. If you are installing a winch, light bar, or filler-panel, install them now before we install the bumper on the Tacoma. To install the filler-panel use two 5/16" nuts, bolts, and washers from the hardware kit.



2. Remove the eleven 10mm bolts along the valance, then use a pry tool to pop the front plastic panel off. Once you remove the panel, you can cut the very small lower valance off. (This will be hidden by the plastic panel if you ever need to go back to stock)



ASSEMBLY

3. After you remove the valance, remove the splash guard.



Next we will remove the crash bar. There is a plastic cover over the crash bar that we will remove by pressing on the clips. Use a 14mm socket to move the 6 nuts holding the crash bar in place. Remove outer trim screws from the bottom of the plastic valance and remove crash bar assembly. You may need to drill out the rivets holding the reinforcement brackets to the



ASSEMBLY

5. Remove the aluminium stand off blocks from the crash bar with a 14mm socket.



6. Using a 14mm socket, remove the 4 bolts holding in the side blocks as shown in the picture below. There is 1 bolt on the drivers side and 3 on the passenger side. The blocks will slide out of the frame.

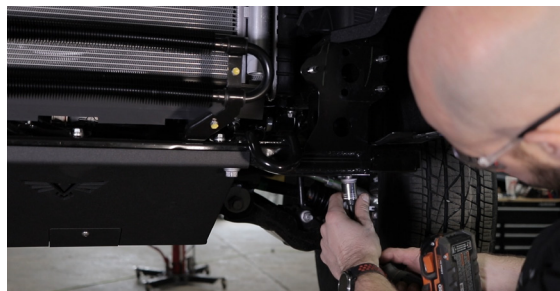
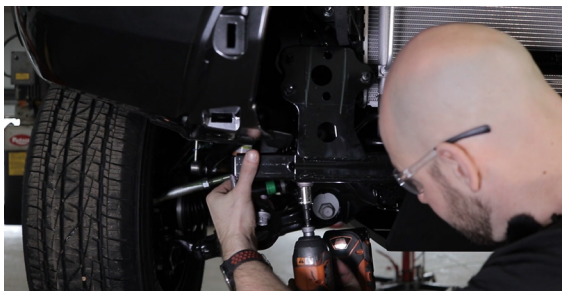

ASSEMBLY

7. Before we can install the bumper we need to move the cooler back. Start by removing the 12mm bolt on both sides of the cooler.

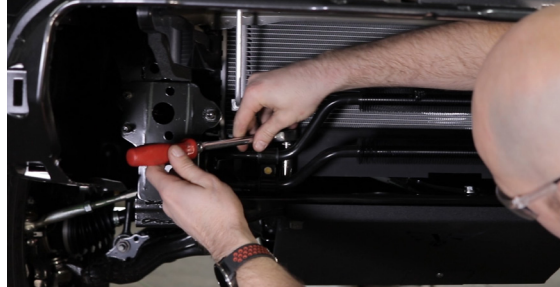
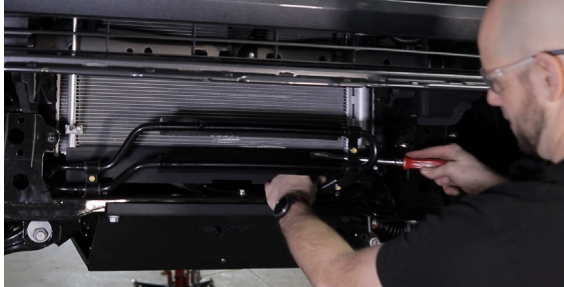

Remove the flap under the passenger side to reach the last 12mm bolt. Install the small bracket we supply with a 5/16" button head bolt. Use the stock bolt to secure the bracket to the frame.

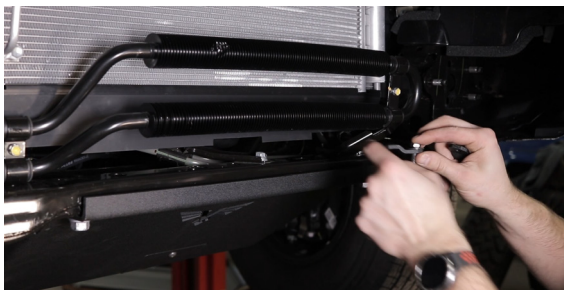
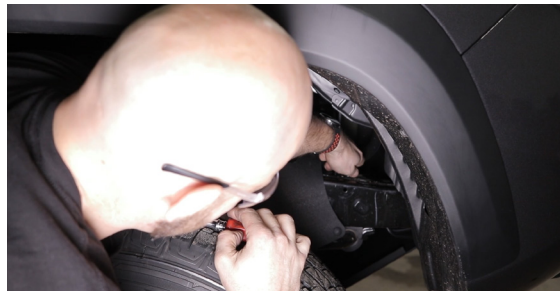

Install the other 2 brackets in the front using a 5/16" button head bolt and the stock bolts we removed earlier. Make sure the brackets are pointed straight back toward the truck.

ASSEMBLY

8. Install the blitz bumper. Have a friend help you lift the Blitz bumper onto the pre-existing bolts. Loosely install 1-2 per side using the factory nuts to hold the bumper in place and then reach underneath the bumper to secure the rest of the nuts.



Using a 3/4" socket, install a 1/2" bolt that we provide on the bottom bracket of the bumper. Secure this bolt with a washer and flange nut.



Use a 14mm socket and tighten the rest of the nuts holding the bumper in place.



ASSEMBLY

9. Reinstall the factory hardware that secures the inner fender liner.



After you secure the inner fender, use a 5/16" drill bit and drill a hole in the plastic that covers the pre-drilled hole in our bumper. Use a 3/16" allen to tighten the 5/16" bolt with a flange nut.



10. Next, install the (2) provided tie-in brackets over the factory studs on the frame (location show below, be sure to do this on each side). You may need to use a hammer to get them to slide on all the way. Use the longer provided 4" hex bolts with a washer and place them through the large cut-outs on the bracket through the frame and place a nut on the back. Once complete, place the (4) factory nuts back onto the studs and tighten those down. Once tight, snug up the 4" hex bolts, but be sure not to over tighten.



ASSEMBLY

2nd Gen Cut 05-11 & 12-15

You will cut just inside of the body line in the center, as shown below. The bumper will completely cover this cut line.

