

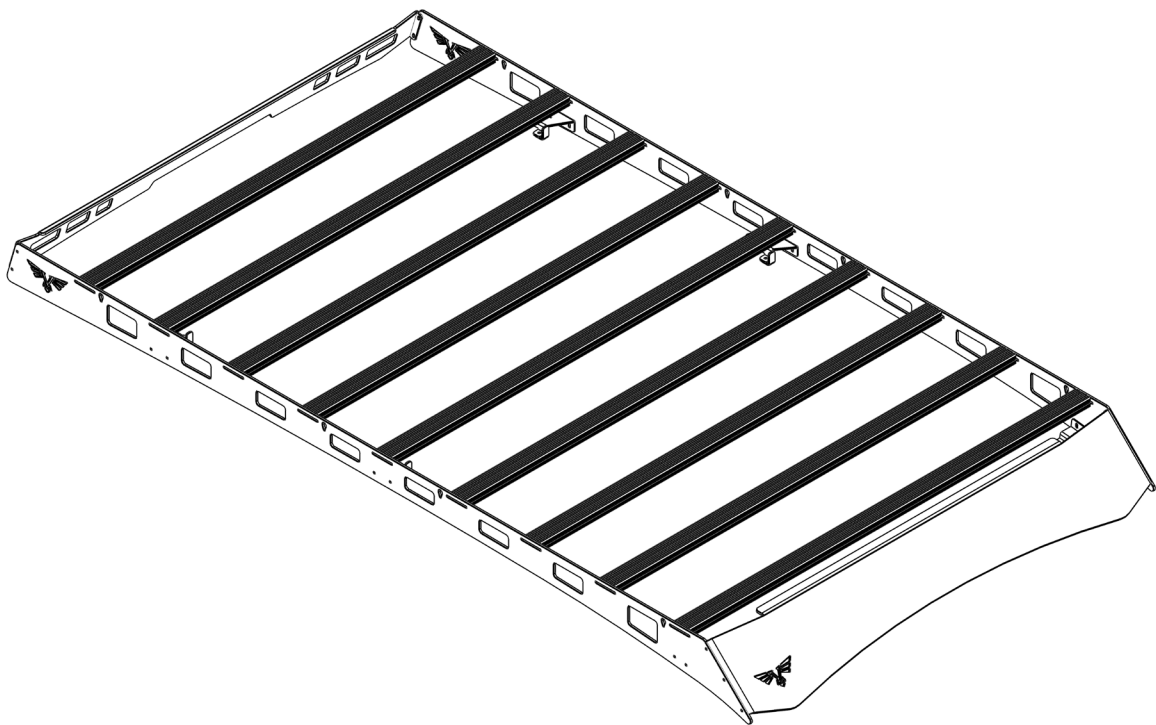

VICTORY 4X4

3RD GEN SEQUOIA ROOF RACK

INSTALL INSTRUCTIONS



Please read the mounting instructions below carefully before attempting to install.

Check out the install video on the product page for factory rack disassembly.

Thank you for purchasing from Victory 4x4! Checkout our website, victory4x4.com for other great off-road products. Be sure to rate and review our product online. If you have any questions or are missing parts, please don't hesitate to call us at 269-459-8447!

INCLUDED HARDWARE

INCLUDED BOLT PACK(S) 046-0052

Note: Some Victory 4x4/JCR Offroad/SquatchProof products share hardware kits. Any extra hardware you may receive that is not listed below can be repurposed or discarded.

62x

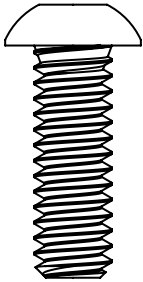

1/4"-20 X 3/4"
Button Head

4x

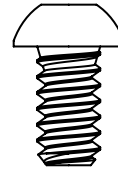

Included with light
bar cutout option.

1/4"-20 X 3/8"
Button Head

22x

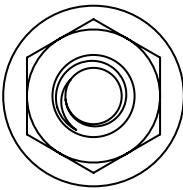

1/4"-20
Serr. Flange Nut

4x



Included with light
bar cutout option.

1/4"-20
T-Nut

62x

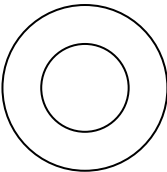

1/4" ID
Washer

12x

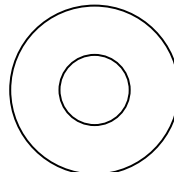

M8 Stainless
USS Washer

12x

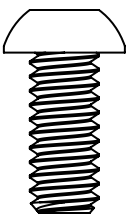

M8-1.25 x 25mm
Button Head

4x

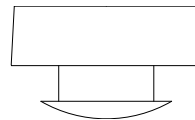

1/2" Rubber
Push in Bumper

16x

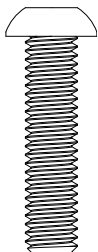

18-8 Stainless
M6 x 1mm Button Head

INCLUDED PARTS

2x



SideRail

9x



54" Crossbar

1x



Rear Fairing

1x

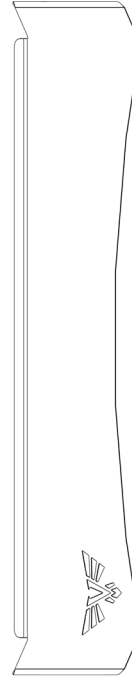

54" 0 Front Fairing

1x

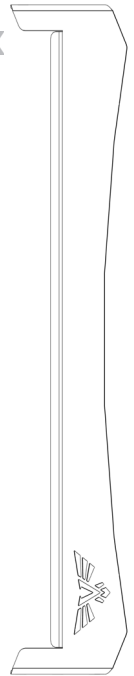

54" 40 Front Fairing

Or

1L/1R

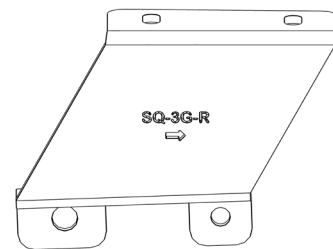

Rear Mount

1L/1R

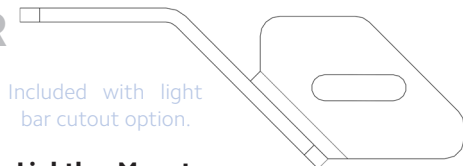

Included with light bar cutout option.

Lightbar Mount

1L/1R

1L/1R

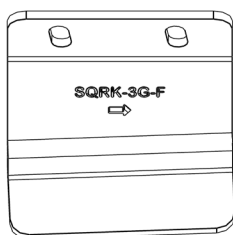

Front Mount

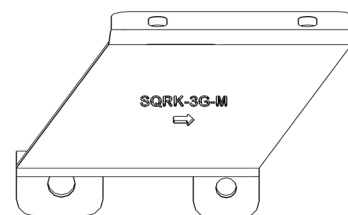

Middle Mount

ASSEMBLY

- 1.** You will need to remove the (2) factory roof rails. Each rail has a plastic cover on each side that will need to be removed with either a plastic pry tool or a flathead screw driver. If your vehicle is not equipped with the roof rails, there will still be (4) plastic covers in the same locations that will need to be removed. With the covers out of the way, take a T-40 torx and you'll be removing (1) bolt from the top of each location.



ASSEMBLY

2. With the hardware removed, you can now remove the roof rails and set them off to the side, there will be a rubber washer underneath where the base of the rails were that will also need to be removed. Next take a 10mm socket and remove the hex bolts also in the same mounting locations, you may need something like a 90 degree pick to prevent the nut from spinning. Be sure to remove the nut after removing the bolt. Do this for all (4) mounting locations.

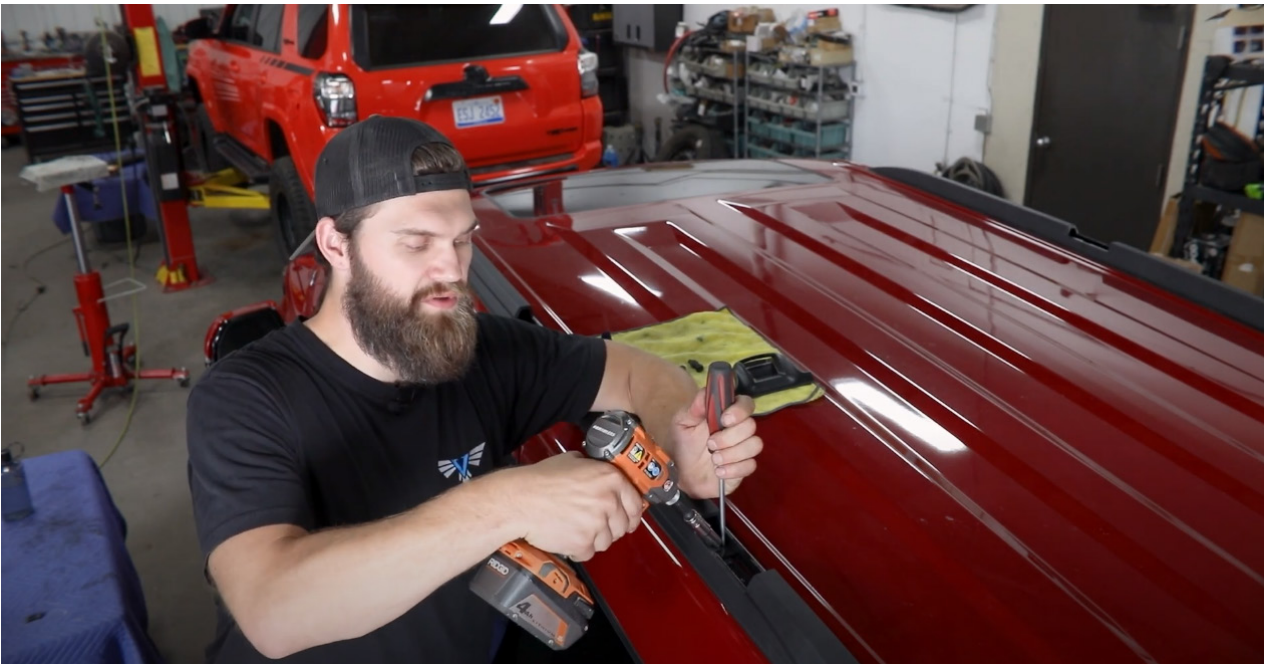

ASSEMBLY

- 3.** Assemble the rack on the ground. Start by mounting the crossbars between the 2 side rails. For this, use the 1/4"-20 X 3/4" button head bolts and the 1/4" ID washers (2 per bar per side). Make sure the machined slot in the rail of the crossbar is facing up, so that you can easily add t-nuts to mount your gear.

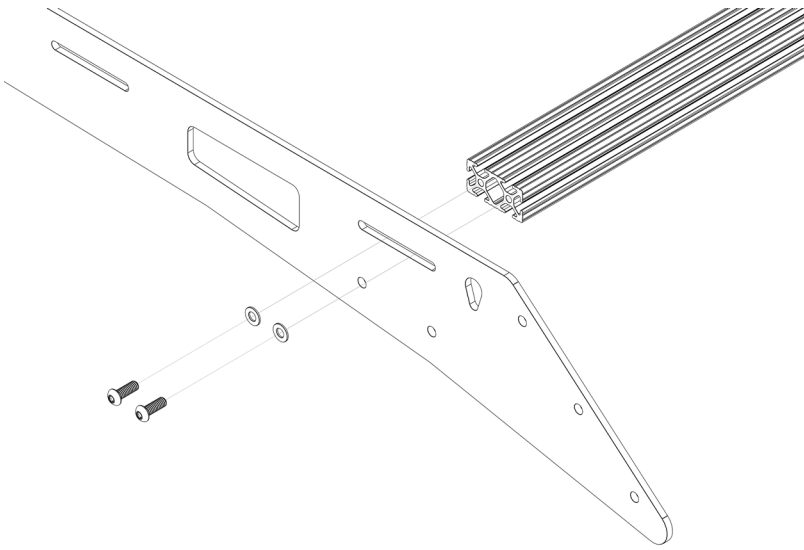

- 4.** Next, you will need to install the provided edge trim to both your front and rear fairings. Starting with the front, you will find two peaks on the bottom edge, align the edge trim roughly 1/4" inch past each peak and cut the trim to length. The goal here is to have the edge trim start and end just outside of the 2 peaks when fully installed. The remaining piece of edge trim will be used on the rear fairing. You will cut that piece in half and firmly press it onto the rear fairing centered on the peaks or anywhere that makes contact with the roof line.

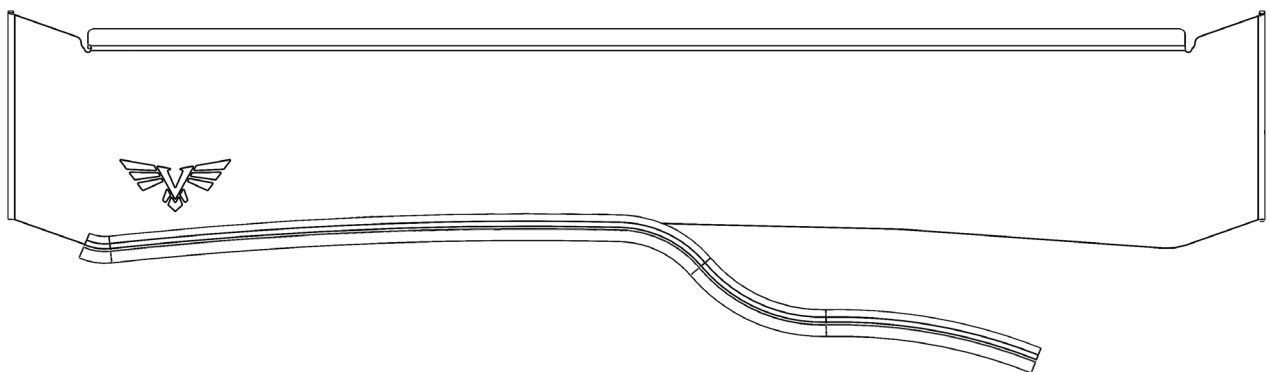

ASSEMBLY

5. Next, mount the front and rear fairings. To do this, use the 1/4"-20 X 3/4" button head bolts, 1/4" ID washers, and 1/4"-20 serrated flange nuts. The front fairing will need 3 of each per side and the rear fairing will need 2 of each per side. When mounting the front fairing, adjust it all the way up to avoid contact with the roof and leave the bolts loose enough to be able to make adjustments once it is on the roof of the vehicle.

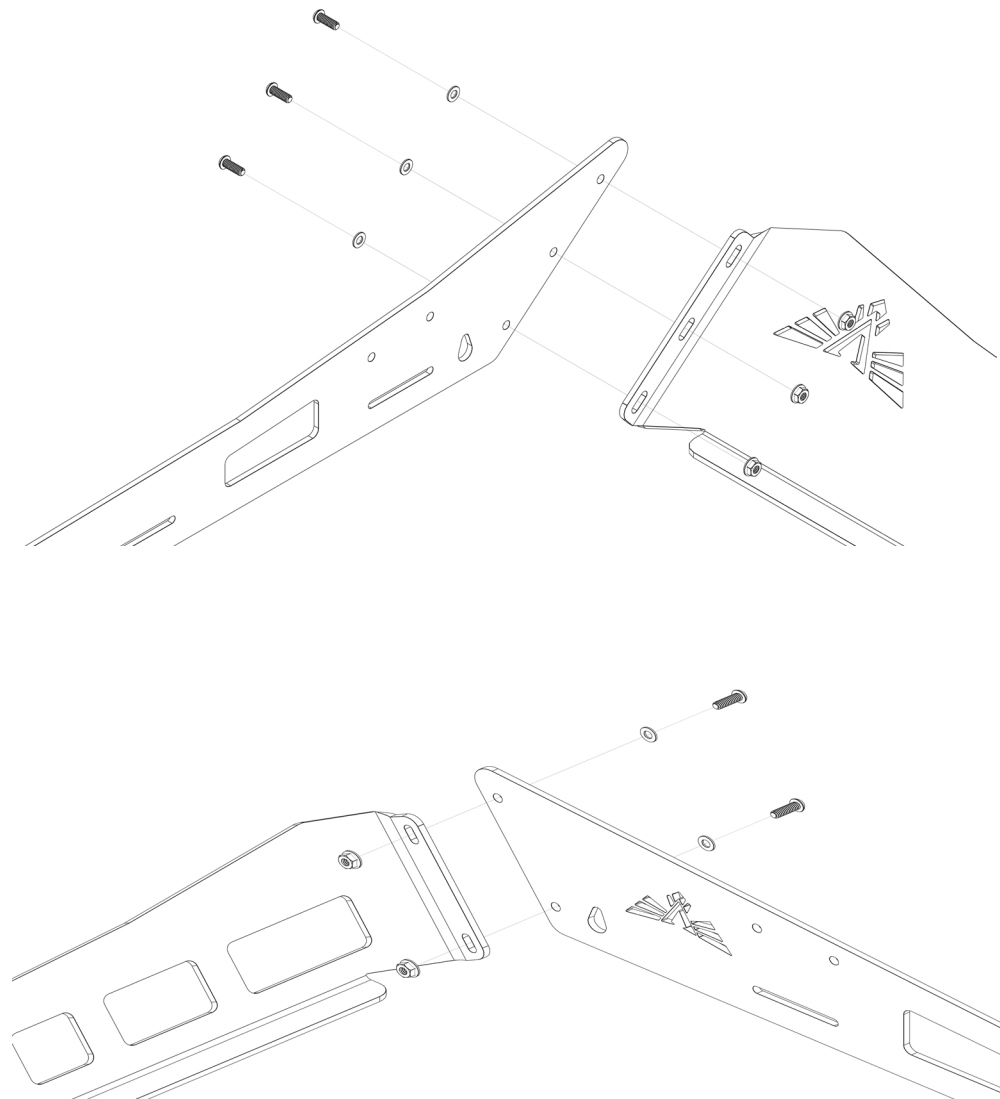

ASSEMBLY

- Next, attach the inner mounts to the inside of the side rails using the 1/4"-20 X 3/4" button head bolts, 1/4" ID washers, and 1/4"-20 serrated flange nuts as shown in the orientation below. All of the mounts will have arrows cut into them that need to be pointed toward the front of the vehicle. Each mount will also have a letter etched into it referencing if it is the front (F), middle (M) or rear (R) mount. Repeat this on both sides.

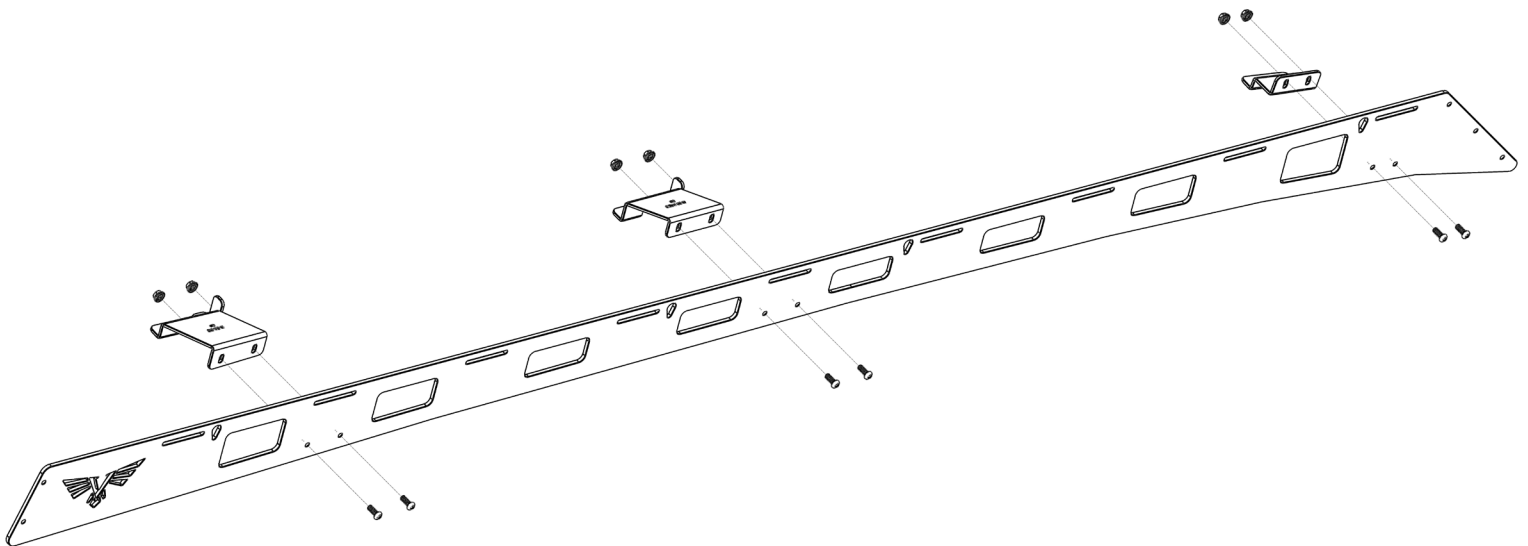

- Next, put the assembled rack onto your roof, making sure that the mounts are on the inside of the cut outs in the plastic where the factory roof rails were, or the plastic covers. Then, position the rack wherever you would like on the roof. We recommend positioning it so that there is an even gap between the bottom edge of the side rails and the top of the roof.

ASSEMBLY

8. The middle and rear mounts will all install the same. Take a provided 8mm button head and a washer and thread it through the bracket and into the factory threaded hole on the roof. With that loosely started, take one of the provided nut tabs and install it to the other hole in the bracket, where the hex bolt and nut were removed previously. This is shown in the orientation below, using a provided 1/4" button head and washer. Repeat this on all (4) mounting locations.

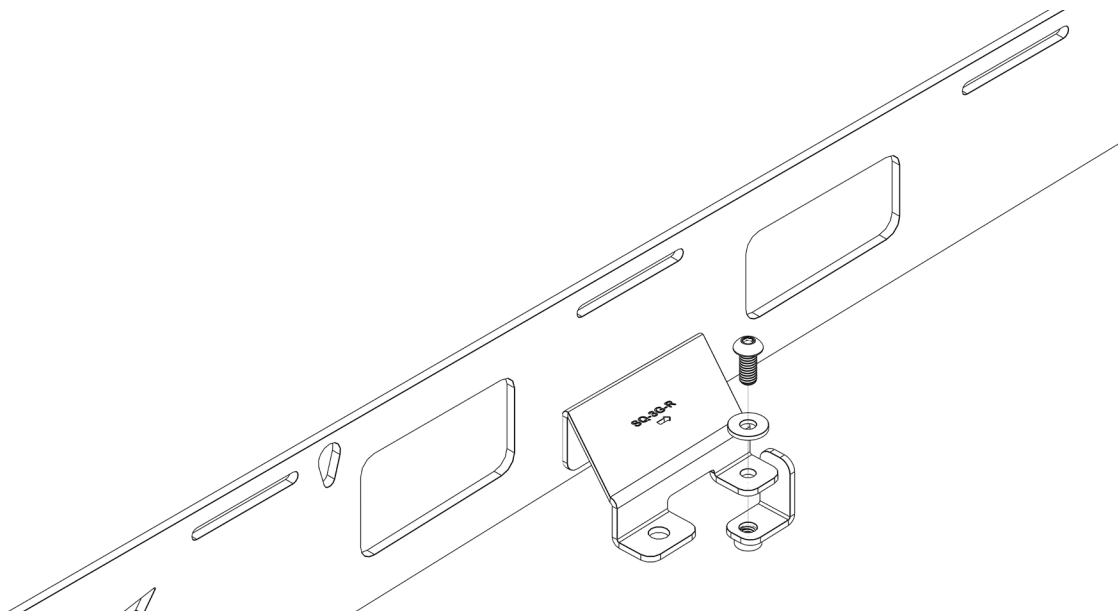

ASSEMBLY

9. With both middle and rear mounts partially bolted on, take a 5/32 hex and tighten the front bolt going into the nut tab. Once that is tight, do the same to the rear bolt in the bracket going into the factory thread, using a 5mm hex. Repeat this process for the remaining (3) mounts.
10. Next, we will be installing the front mounts. These will rest inside of the rain channel, and will be using a piece of provided double sided 3M tape on the bottom flange of the bracket. Be sure to trim the piece of tape to length before sticking it to the bottom of the mounting bracket. We recommend cleaning off the bottom of the bracket and the inside of the rain channel with rubbing alcohol before applying the tape to your bracket.



ASSEMBLY

- 11.** With all of the mounts in place, now is the time to go around and adjust the overall appearance and height of the rack if desired, by loosening the front and rear fairings before any adjustment. You should adjust the front and rear fairings down as far as possible, so they are both firmly planted on the roof line. Once the rack is in the desired position, make sure to go around tighten down all of your hardware to complete your install.



40" LIGHT BAR ASSEMBLY

- 1** Slide 2 t-nuts into each of the channels on the top side of the front-most crossbar using the slots. Then, place each light bar mount over one pair of t-nuts and loosely bolt it in place using the 1/4"-20 X 3/8" button heads.

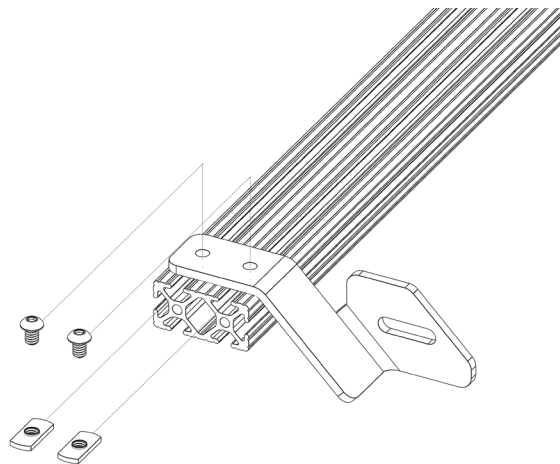

- 2** Next, place your light bar between the mounts and mount it in the slots using the hardware provided with the light bar. After that is firmly in position, make any adjustments to the positioning necessary to center the light bar on the rack. Depending on the rack and light bar, you may need to adjust the position of the cross bar in its slot as well.

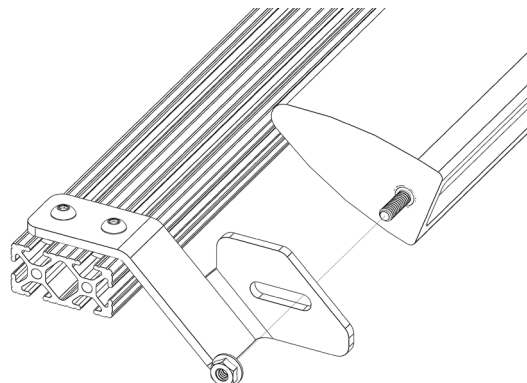

DIMENSIONS

