

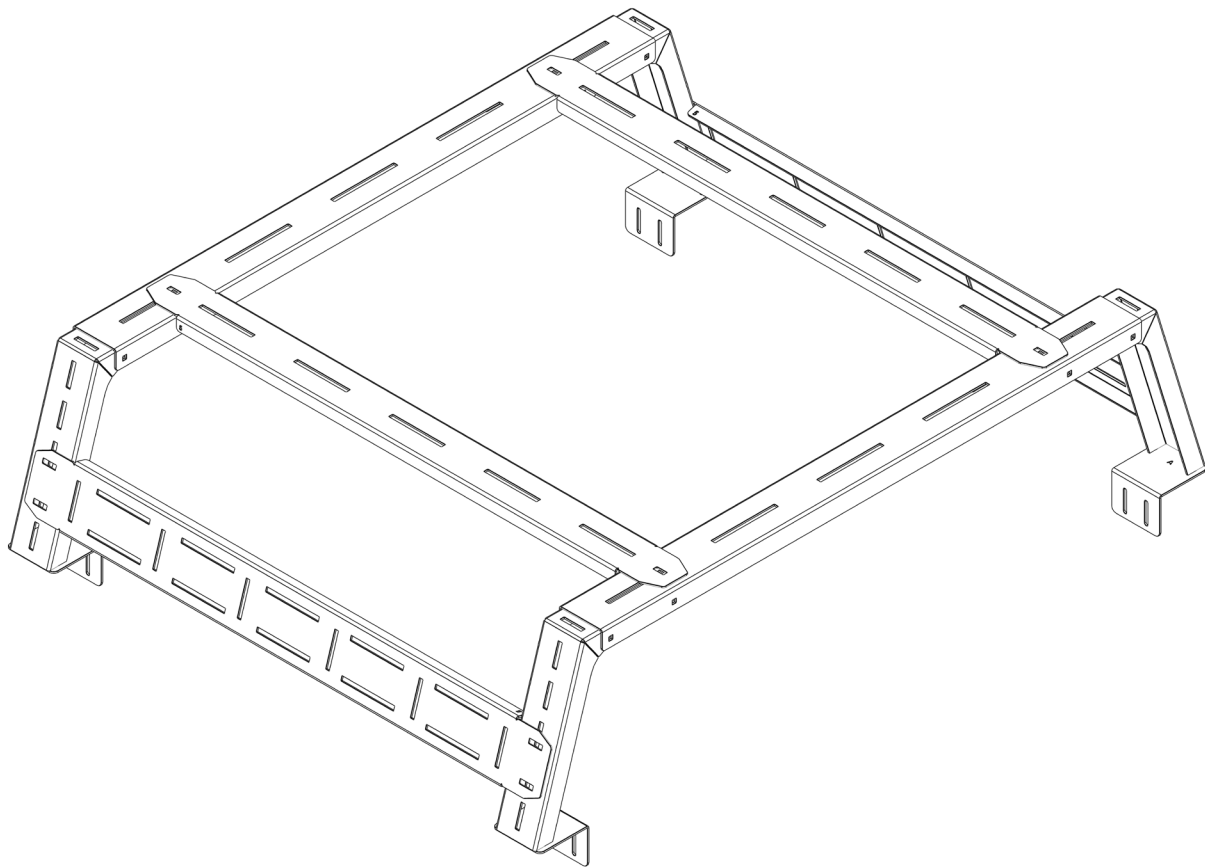

VICTORY 4X4

# ADVENTURE BED RACK

## INSTALL INSTRUCTIONS



**Please read the mounting instructions below carefully before attempting to install.**

**Be sure to check out the install video on the product page, if available.**

Thank you for purchasing from Victory 4x4! Checkout our website, [victory4x4.com](http://victory4x4.com) for other great off-road products. Be sure to rate and review our product online. If you have any questions or are missing parts, please don't hesitate to call us at 269-459-8447!

# INCLUDED HARDWARE

28x

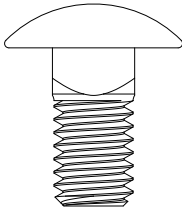

3/8"-16 X 3/4" Long  
Carriage Bolt

28x

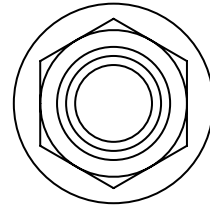

3/8"-16  
Flange Locknut

8x

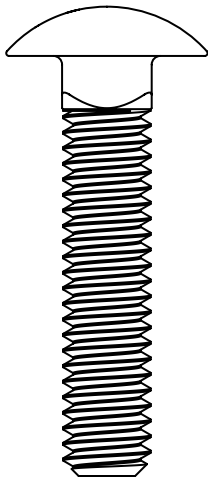

5/16"-18 X 1-1/2"  
Carriage Bolt

8x

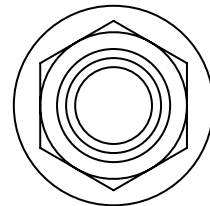

5/16"-18  
Flange Locknut

# INCLUDED PARTS

2x

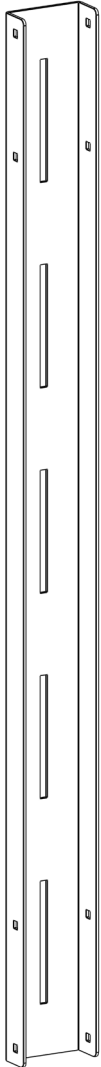

2x

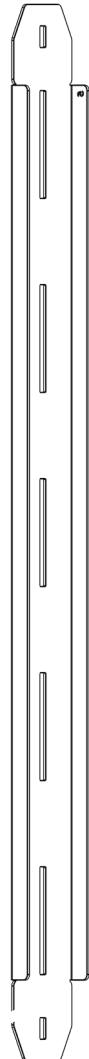

2x

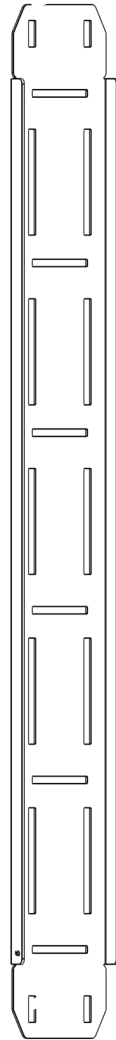

4x

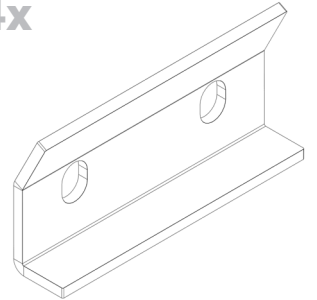

4x



4x

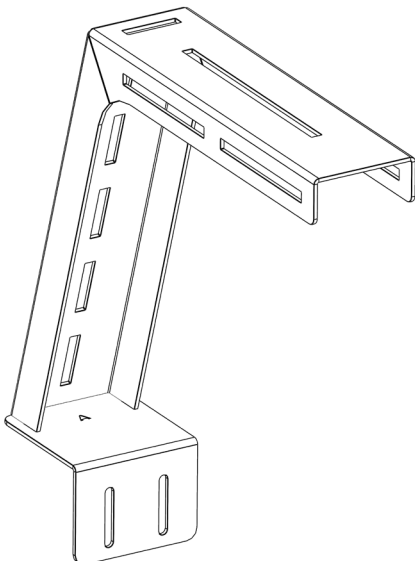

# ASSEMBLY

- 1.** How you begin the install depends on whether or not you have a trail rail system in the bed of your vehicle. If you do, insert a provided 5/16"-18 x 1-1/2" carriage bolt through each hole in the small rectangular spacer and slide that into the trail rail. Do that 3 more times, then you can mount the legs of the bed rack using the 5/16"-18 locking flange nuts. Leave these somewhat loose for now so you can adjust the width in order to fit the side crossbars in step 4.

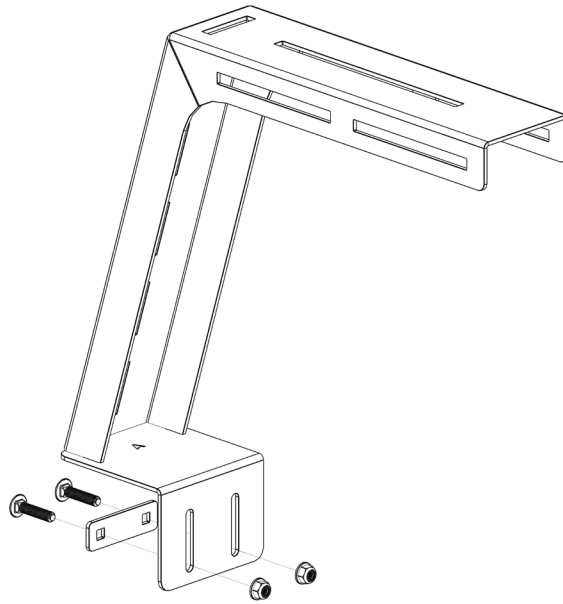

- 2.** If you do not have the trail rail system, you will need to clamp the legs to the side of the bed. For this method, we recommend putting the rack together before putting the legs on the bed of the vehicle. Only do this if you can get help lifting it into place after it is assembled. If you are putting the rack together alone, attach the legs to the bed first. See step 6 on page 8 for more instructions on this.

# ASSEMBLY

3. Next, mount the open-ended crossbars between the each of the front and rear legs using the provided 3/8"-16, 3/4" long carriage bolts and 3/8"-16 locking flange nuts on the inside. Assemble as shown in the orientation below. You may need to adjust the width and position of the middle crossbar depending on your vehicle.

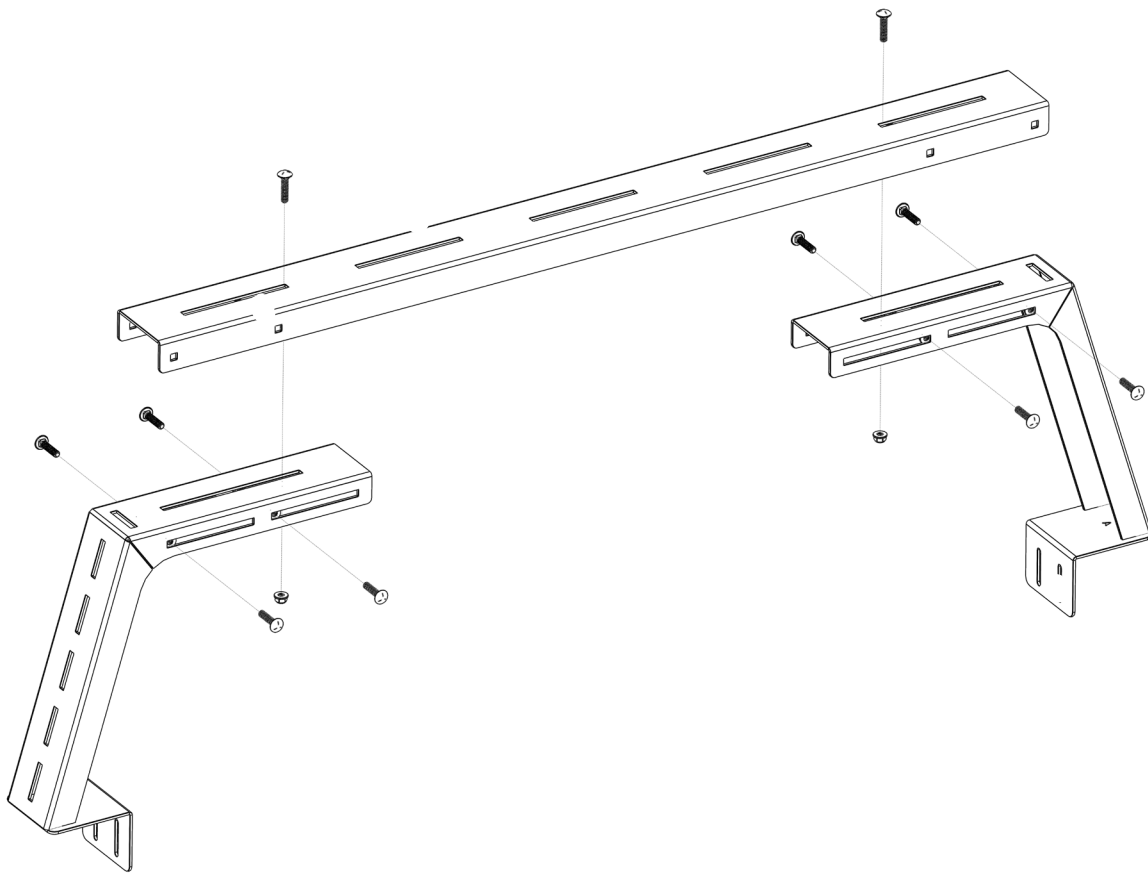

# ASSEMBLY

4. Next, connect the front and rear legs using the wider crossbar using the provided 3/8"-16 x 3/4" carriage bolts and 3/8"-16 locking flange nuts. This bar mounts to the outside of the front and rear legs and gives you a few different mounting options to choose from. The flanges should be toward the inside of the rack. If you are assembling the rack on the bed, you may need to slide the legs forwards or backwards in order to attach the bar. Once the bar is attached you can tighten the legs fully into place. Try to tighten each bolt evenly in order to best secure the bed rack. Once secure, make sure to go back and tighten down your legs to the bed now that the width is correct.

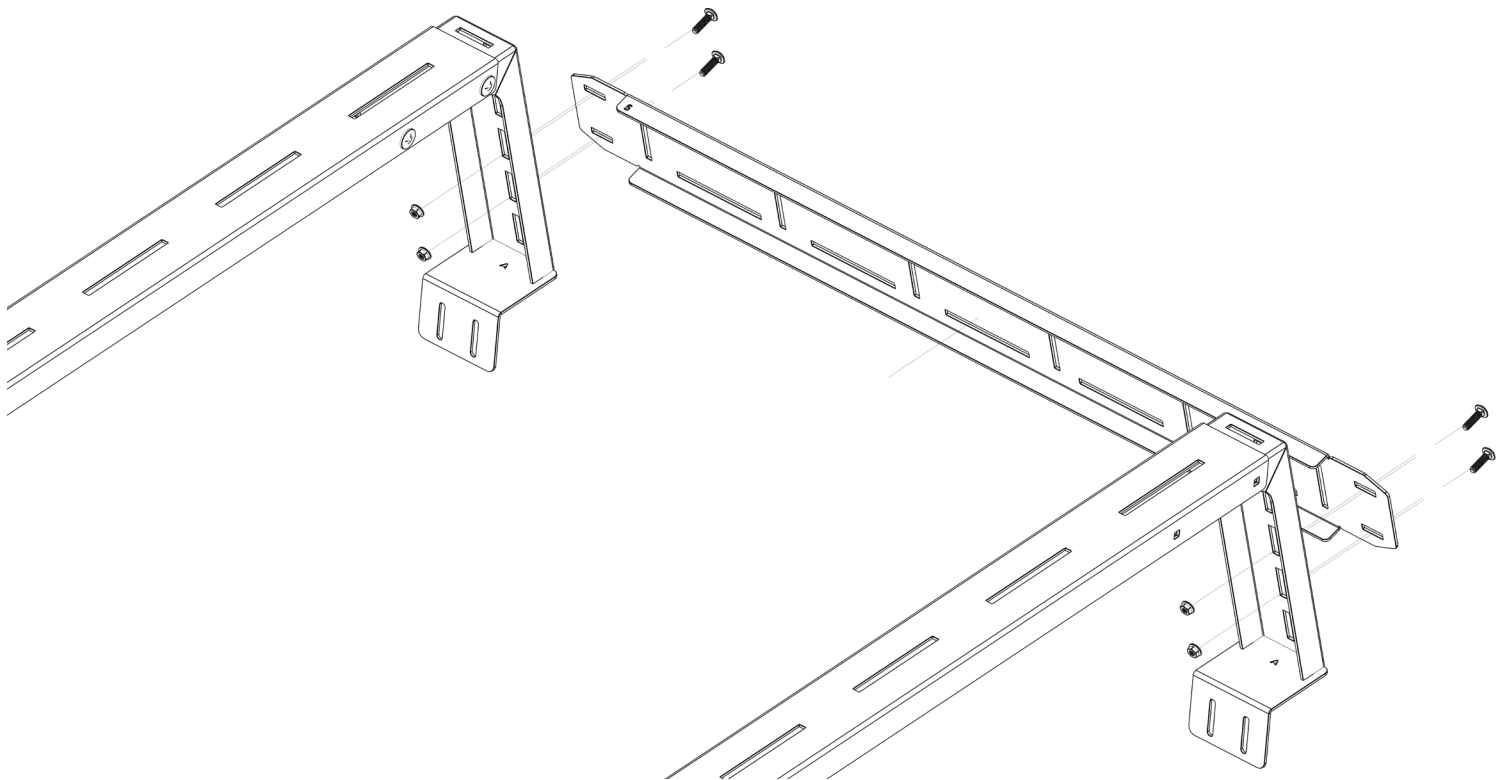

# ASSEMBLY

5. Next, mount the remaining bars vertically between the two top horizontal crossbars. Choose which slots you want to mount to in the top crossbar and then use the provided  $3/8''$ -16 x  $3/4''$  carriage bolts and  $3/8''$ -16 locking flange nuts to mount them in position. The open side should be on the bottom with the flange pointing down, as shown below.

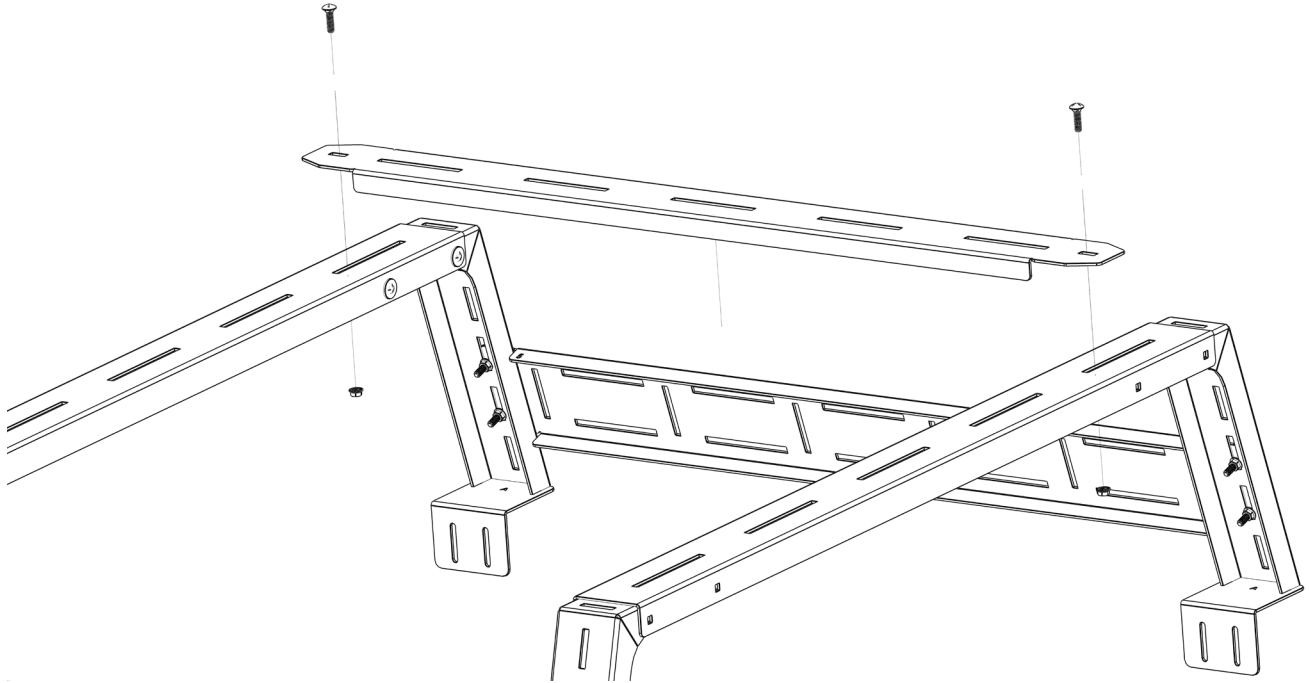

# ASSEMBLY

6. Finally, if you need to clamp the legs to the bed, place the assembled bed rack into the bed and loosely attach the c shaped bracket to the back of the bottom of each of the legs using the 5/16"-18 x 1-1/2" carriage bolts and 5/16"-18 locking flange nuts. Make sure the 90-degree bend is on the bottom and the carriage bolts go through the back side of the c shaped bracket. Finally, push the c shaped brackets up until the edge of the bed is between the brackets and the bottom of the legs and tighten them all into place, clamping the bed rack onto the bed. Try to tighten each bolt evenly in order to best secure the bed rack. If you are doing this step before assembling the rack, it may be easiest to attach the c shaped brackets to the legs before setting them into place.

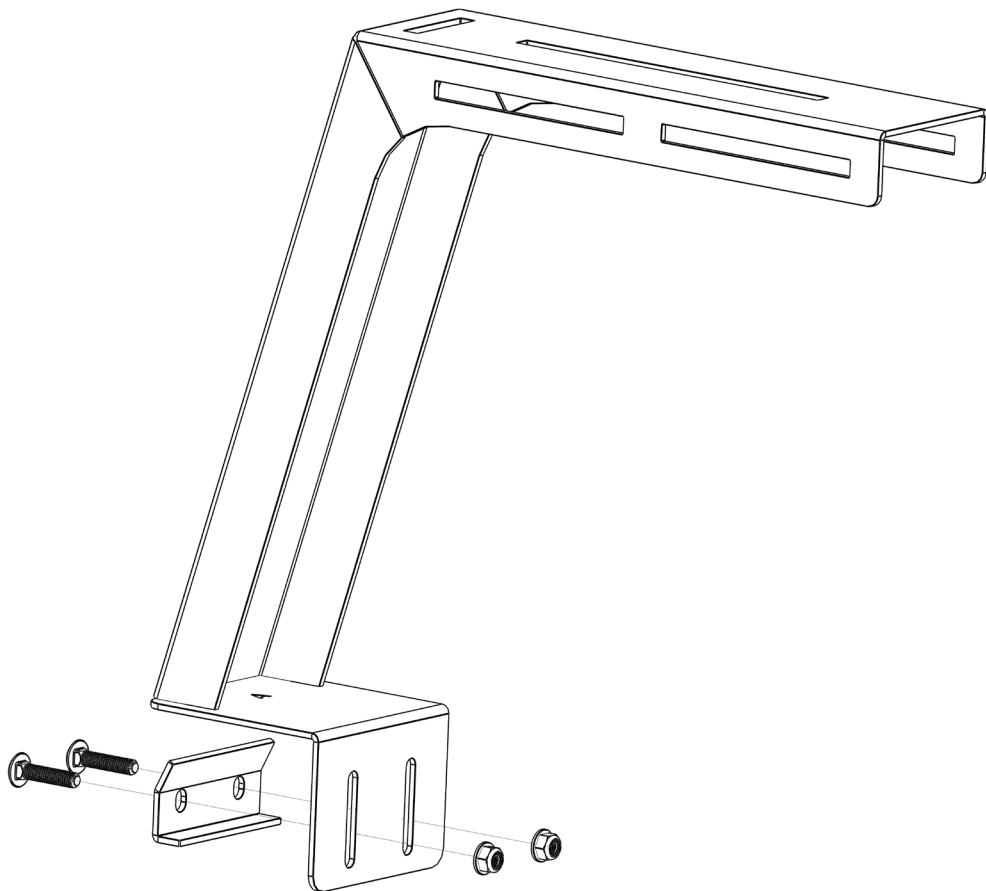



# DIMENSIONS

**NOTE:** The 5' rack need 48" long of trail rail or clampable bed space in order to mount, while the 6' rack needs 60" long of trail rail or clampable bed space to mount.

