



VICTORY4X4

03-09 GX 470

DIY FRONT BUMPER

INSTALL INSTRUCTIONS

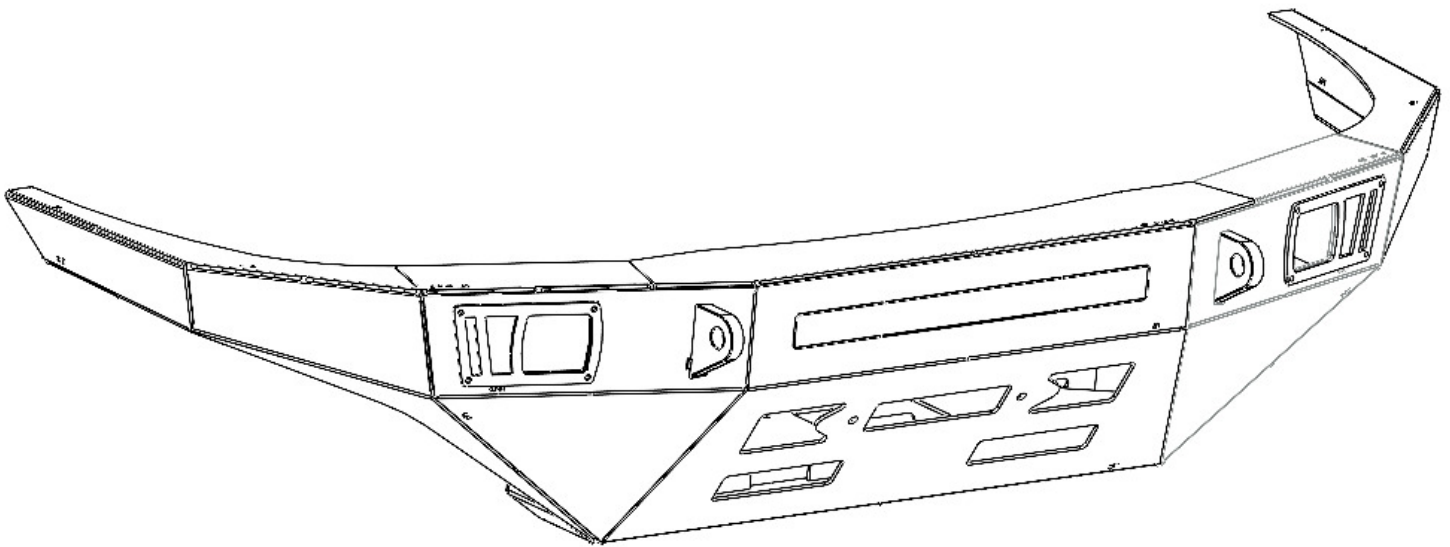

Please read the mounting instructions below carefully before attempting to install.

Be sure to check out the install video on the product page, if available.

Thank you for purchasing from Victory 4x4! Checkout our website, victory4x4.com for other great off-road products. Be sure to rate and review our product online. If you have any questions or are missing parts, please don't hesitate to call us at 269-459-8447!

INCLUDED HARDWARE

INCLUDED BOLT PACK(S) 046-0083

Note: Some Victory 4x4/JCR Offroad/SquatchProof products share hardware kits. Any extra hardware you may receive that is not listed below can be repurposed or discarded.

4x

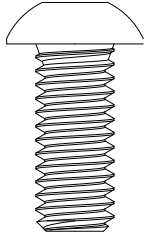

5/16-18-3/4 Button Head

4x

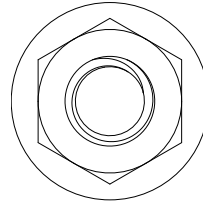

5/16-18 Serr. Flange Nut

8x

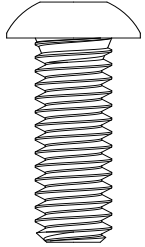

1/4-20-3/4 Button Head

8x

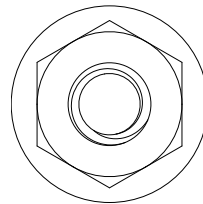

1/4"-20 Locknut

4x

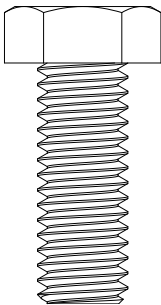

3/8"-16 Thread Size, 1" Long
Hex Head Screw

4x

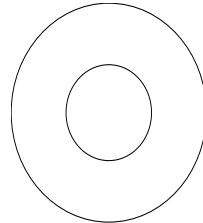

3/8 Uss Flat Washer Znc

4x

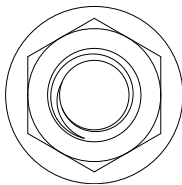

3/8-16 Serr. Flange Nut

2x



5/8" x 4" Long Hex Bolt

2x

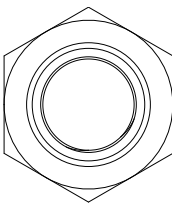

5/8-11 Hex Lock Nut

4x

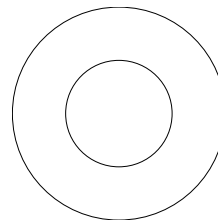

5/8" SAE Flat Washer

INCLUDED PARTS

1x #1 Center Section

2x #2 Upright Supports

2x #3 Mounting Brackets

1x #4 Winch Tray

2x #5 Inside Wing Pieces

2x #6 Outside Wing Pieces

2x #7 Cube Light Mounts

2x #8 Lightbar Mounts

2x #9 Bezel Pieces

2x #10 Headlight Bezels

2x #11 Frame Tie-Ins

2x D-Rings

ASSEMBLY

1. Before you start, **note that each of the bend angles are etched on the part along the slit lines.**

Start by bending all of your parts on the slit lines according to the angles called out. Below you will see each part and how they should look after they are bent. Note that there will be (2) part 5s and (2) part 6s that are lefts and rights, and will need to be mirror images of one another once bent.

1

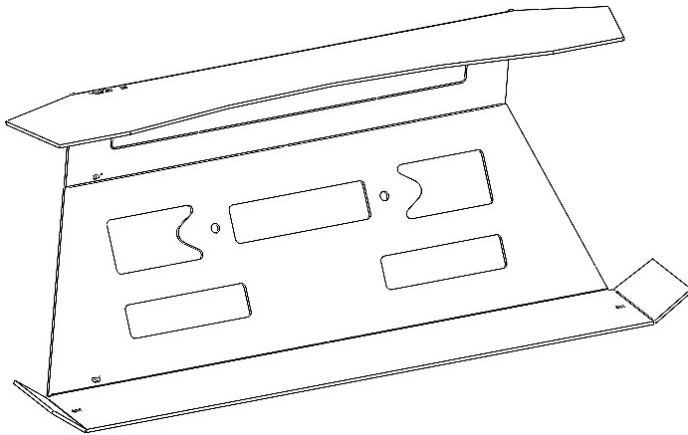

(2x) 3

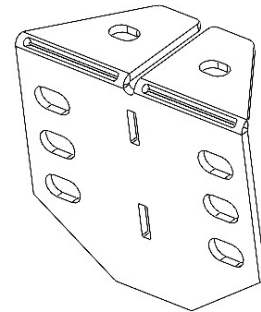

4

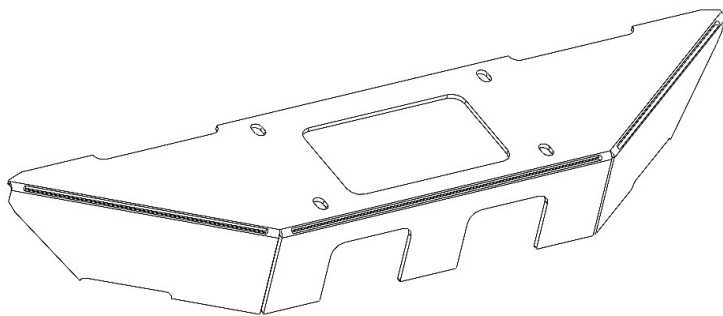

(L&R) 5

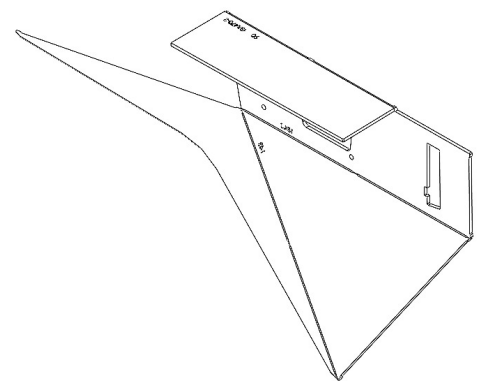

(L&R) 6

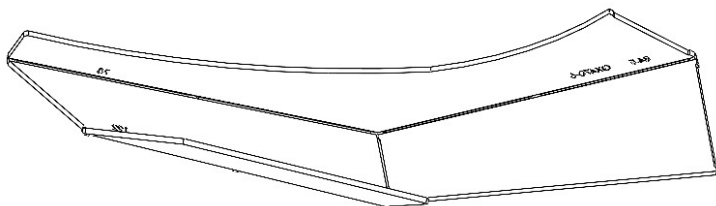

(2x) 11

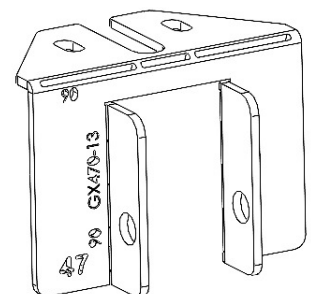

ASSEMBLY

2. Once all of your parts are bent to the correct angles, tack weld and assemble parts 1,2,3 & 4 using the tabs and making sure everything is square to one another. See reference picture below for an idea of what it should look like.

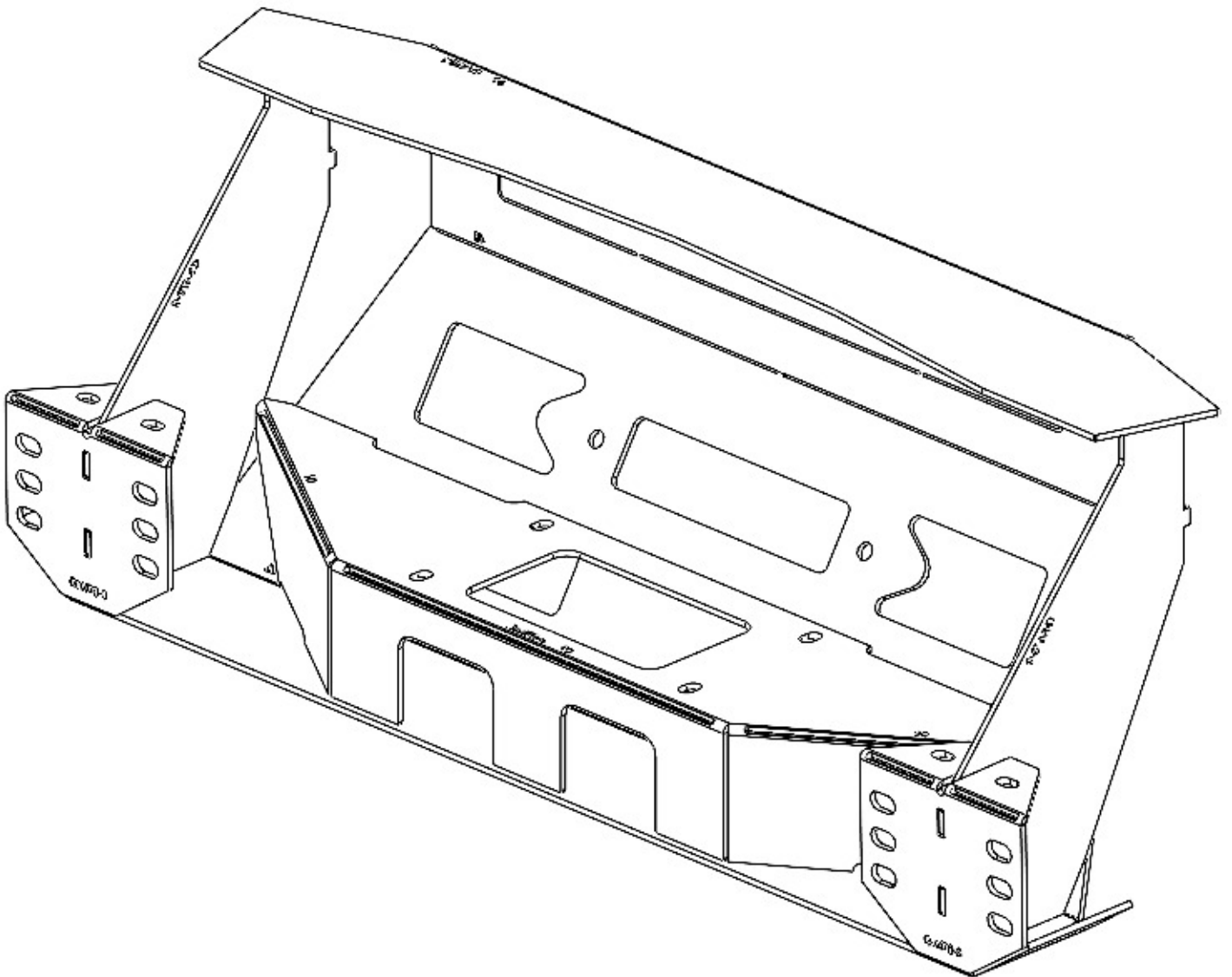

ASSEMBLY

3. Now that your center section shell is tacked together, loosey bolt it onto the truck centered on the slots and snug the bolts down.
4. Using the headlights, grille and fenders as a reference, tack on both sides for parts 5 & 6 working from the center out. You're looking for a uniform gap between $3/8''$ and $5/8''$ between each piece and the body. See reference pictures below of an exploded view for added help.

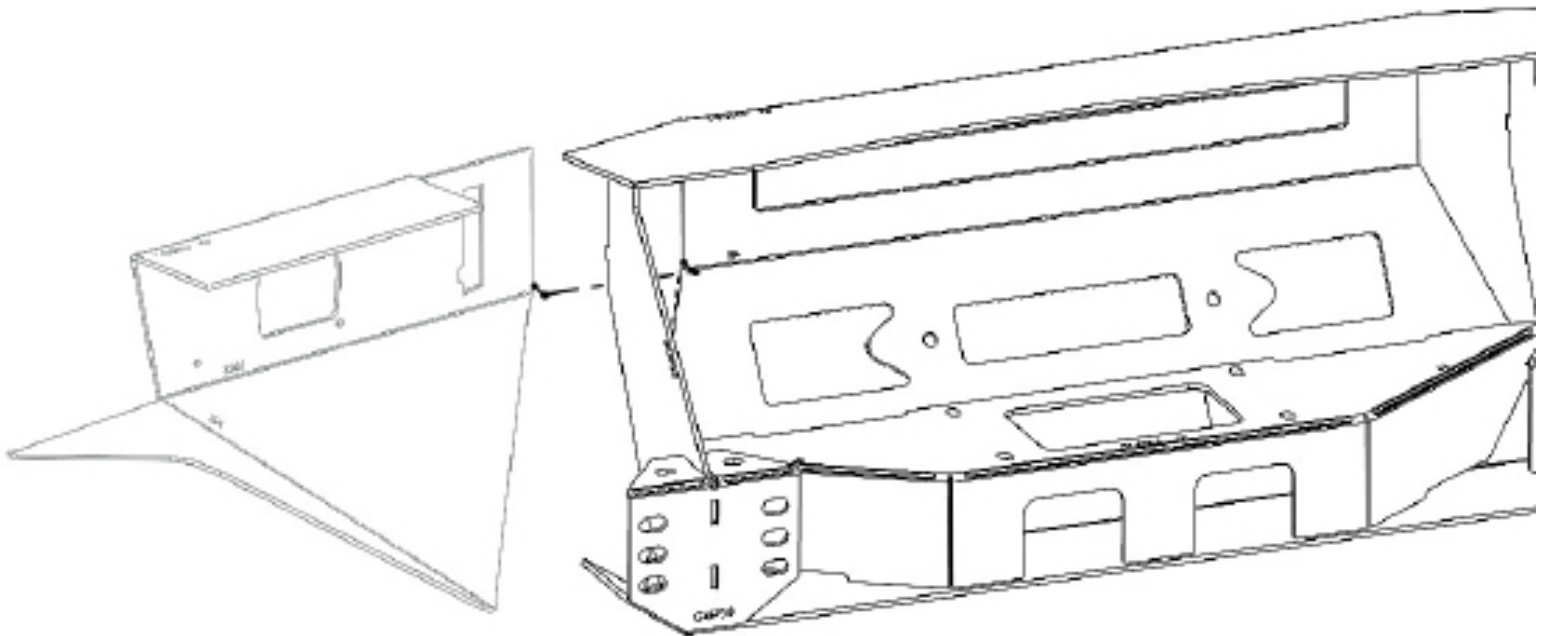

How it should look after both part 5's are tacked onto the shell.

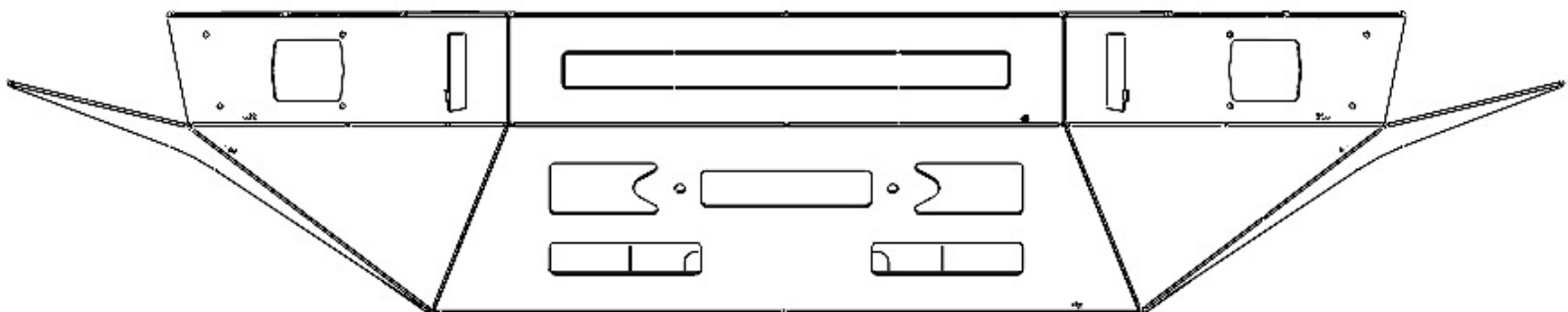

ASSEMBLY

4. Continued

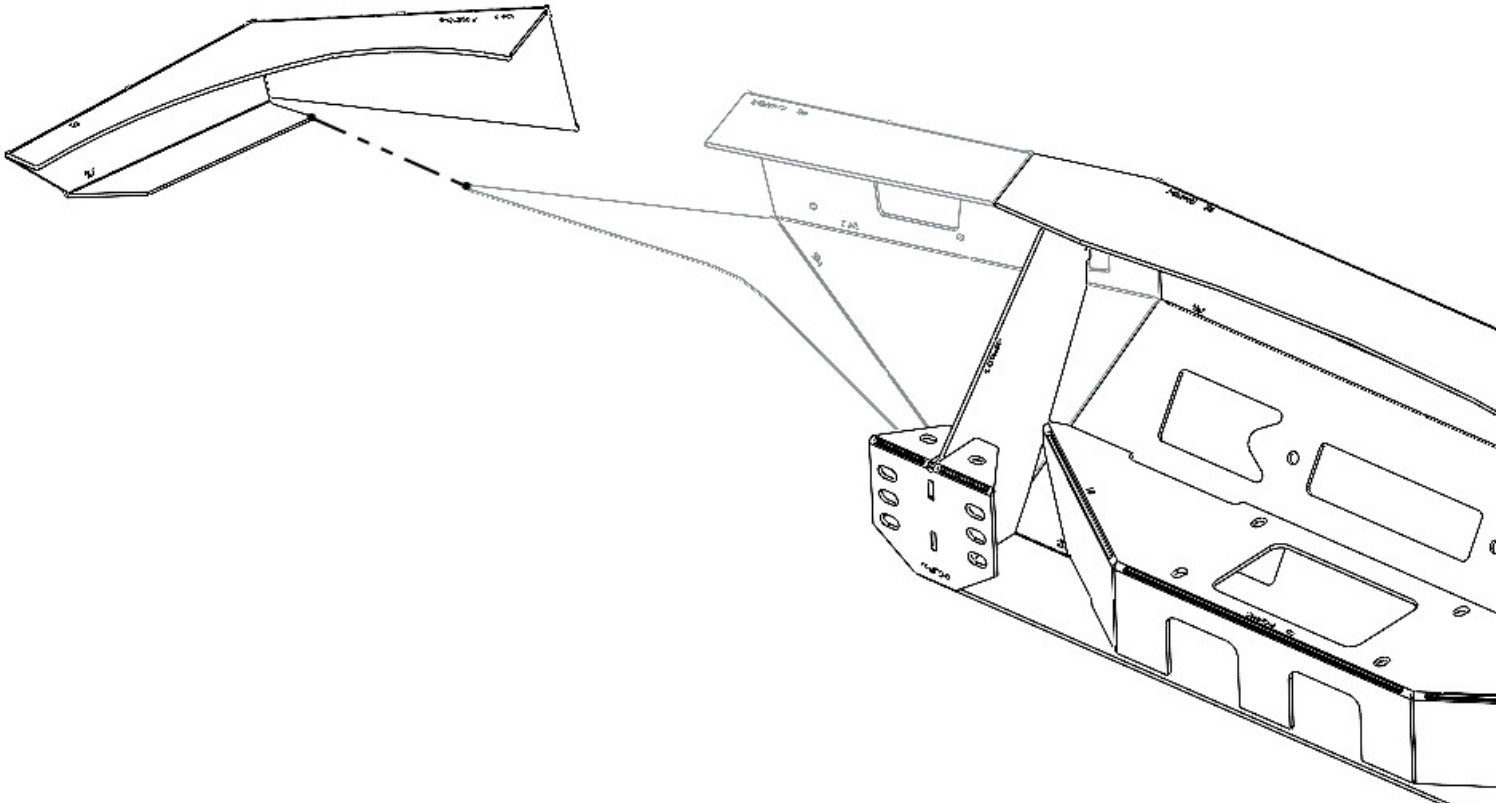

How it should look after both part 6's are tacked onto the shell.

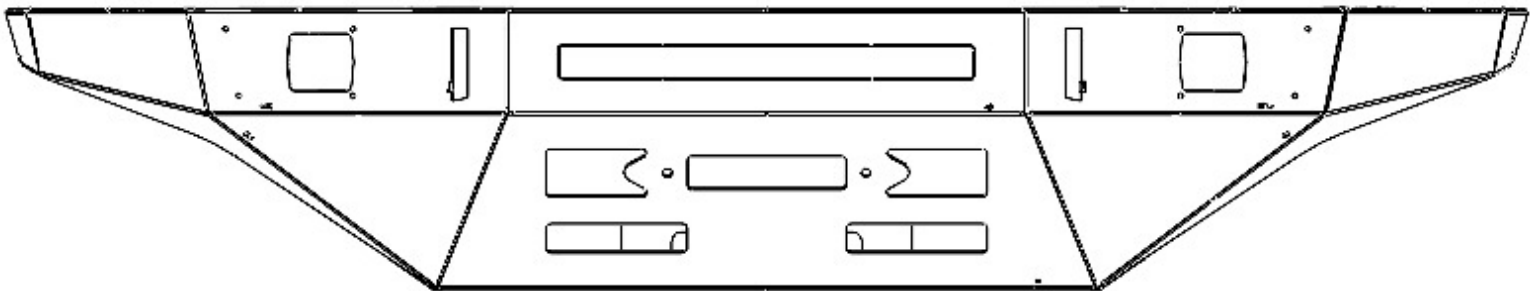

ASSEMBLY

5. Now that the bumper is fully tacked together on the truck, it is time to fully weld the seams. Keep in mind, with all of the heat produced by fully welding this bumper, you may experience some deformation or warping when welding. To avoid this, you may choose to do some of the welding with the bumper still mounted to the vehicle, to ensure it holds its desired shape. If you do remove the bumper to weld it fully, we recommend jumping around to different locations to avoid concentrating heat in one area. Clamping a rigid straight edge to the top of the wings can help prevent warping as well.
6. After the whole bumper has been fully welded together, using the cube lights of your choosing to set the height of your mounts, take the mounts (part 7) and weld them centered under the cube light cutouts on each side of the bumper, as shown below.

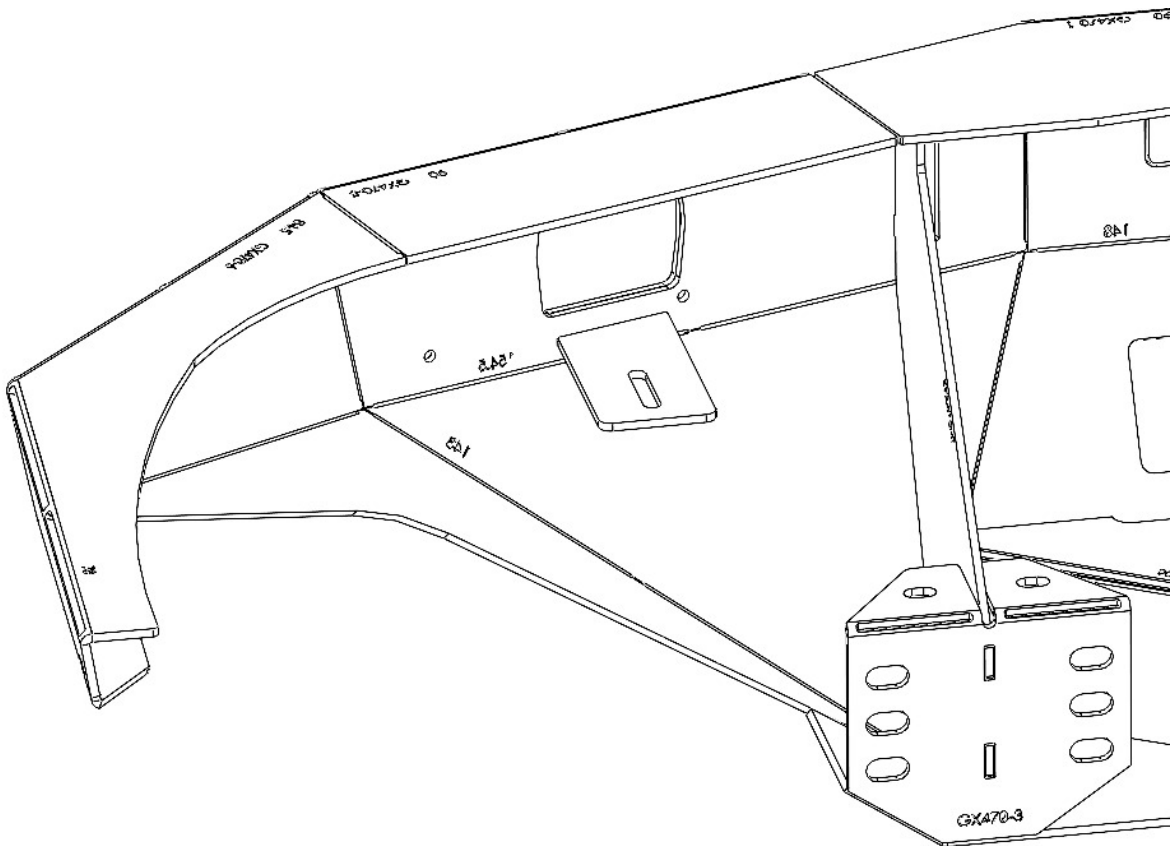

ASSEMBLY

- 7.** If you plan on running a light bar in your bumper, you will need to cut out rest of the light bar opening. Then you will take the lightbar of your choosing, and loosely assemble the tabs (part 8) to the light. Center the lightbar in the cutout and tack weld the tabs. Remove the lightbar before fully welding the tabs into place. Alternativley, if you don't plan on running a light bar, you can weld and grind the cutout closed if you choose.

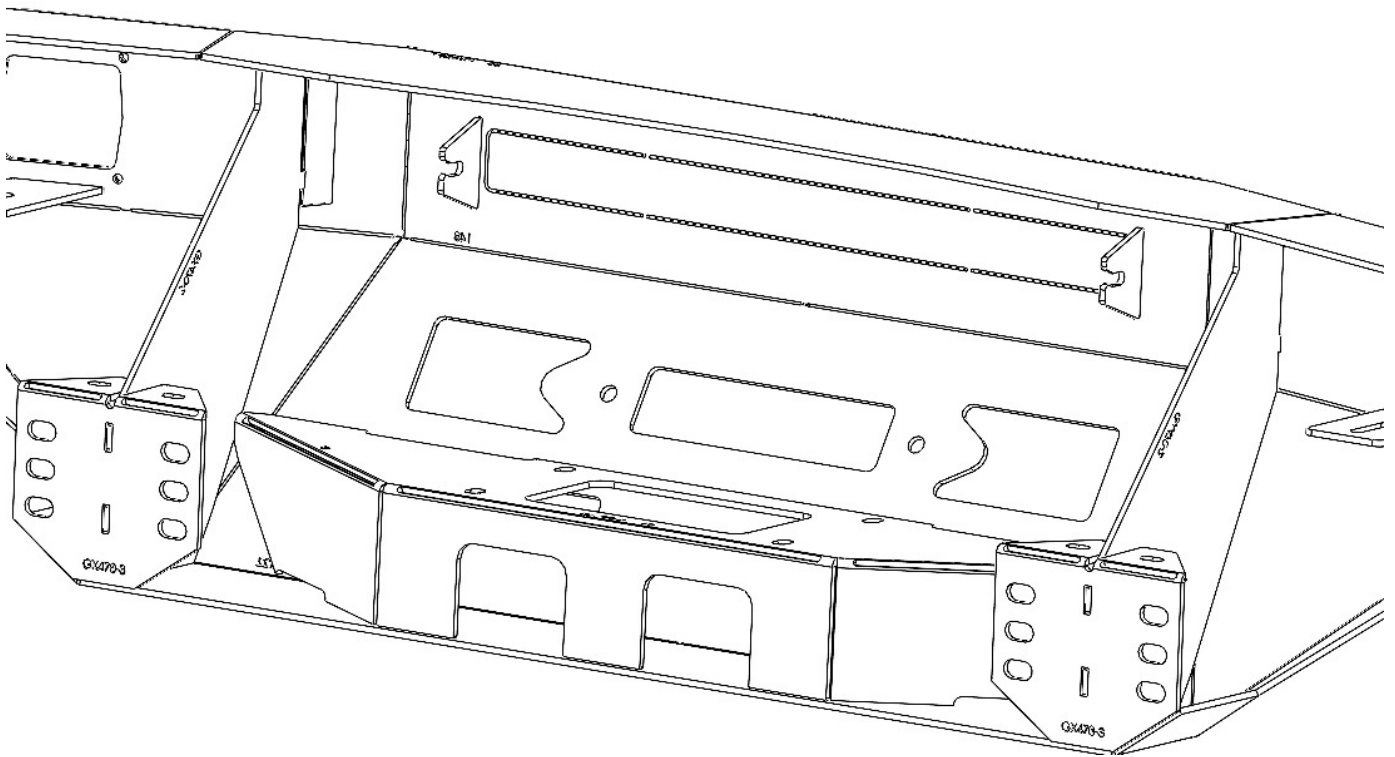

ASSEMBLY

8. Take the two provided cube light bezel pieces (part 9) and the provided hardware and bolt them around the cube light cut outs into the mounting holes, as shown below.

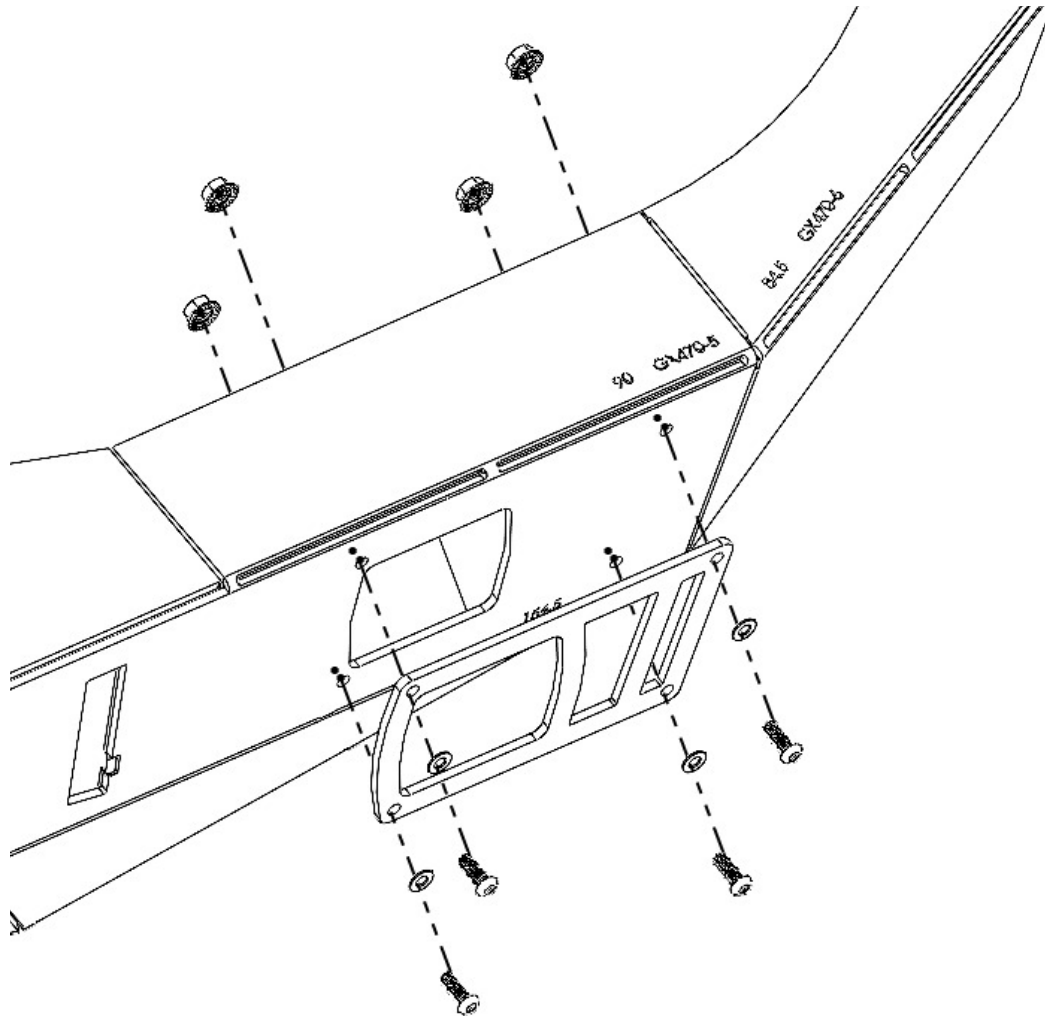

ASSEMBLY

9. Weld the bend line and then place the tie-in brackets over the frame horns. You will be marking and drilling them after the bumper is back on the vehicle.

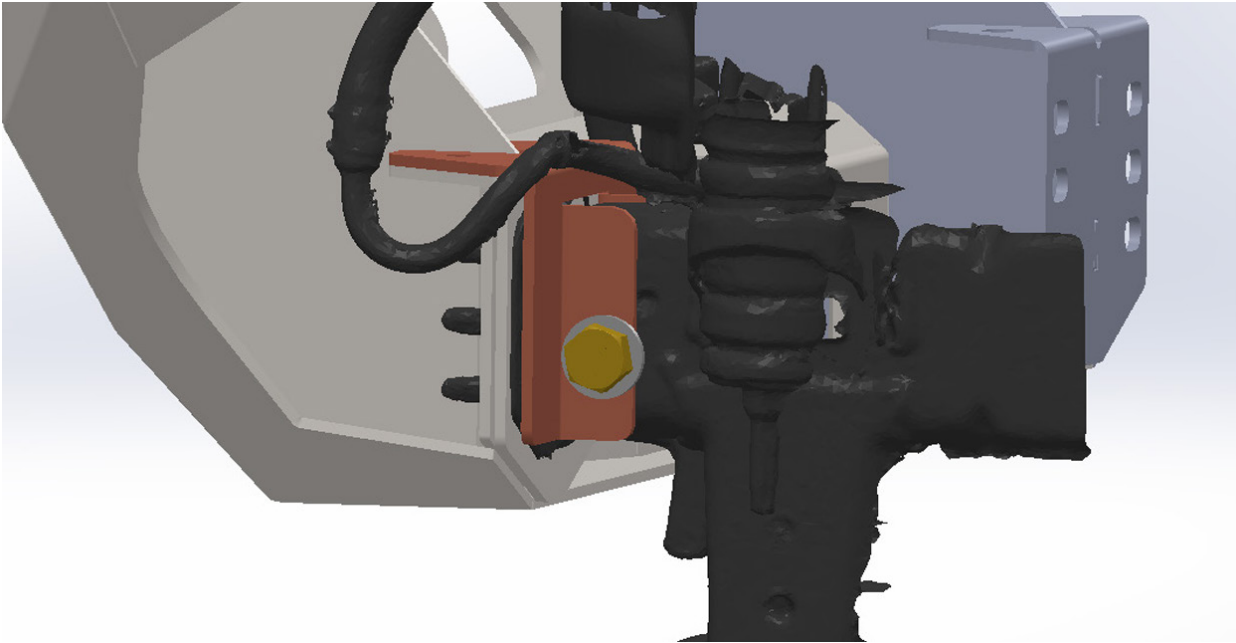

ASSEMBLY

10. Next, you will need to re-mount the bumper to your truck and bend the head light filler panels (part 10) and tack them to the top of your bumper under the headlights with an even gap to the headlight on both sides of the bumper. There is no set degree to bend these as each truck may be different, so this may take a bit of adjustment. When you are happy with the look of it and the gap on each side, fully weld them down onto the bumper.

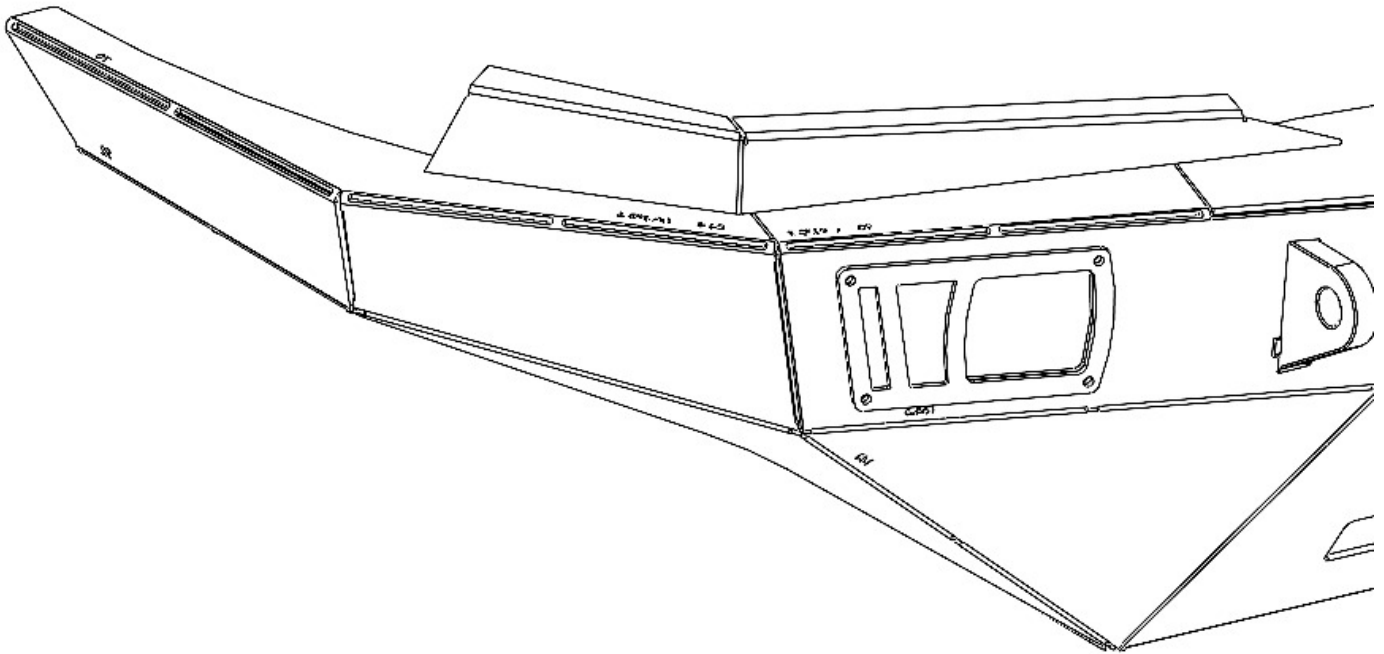

ASSEMBLY

11. Next, put the supplied bolts through the top of the tie-in brackets and the bumper to locate the bracket on the frame. Once located, drill a 5/8" hole through the side of the bracket and the frame rail. Be sure to touch up any exposed metal with paint.

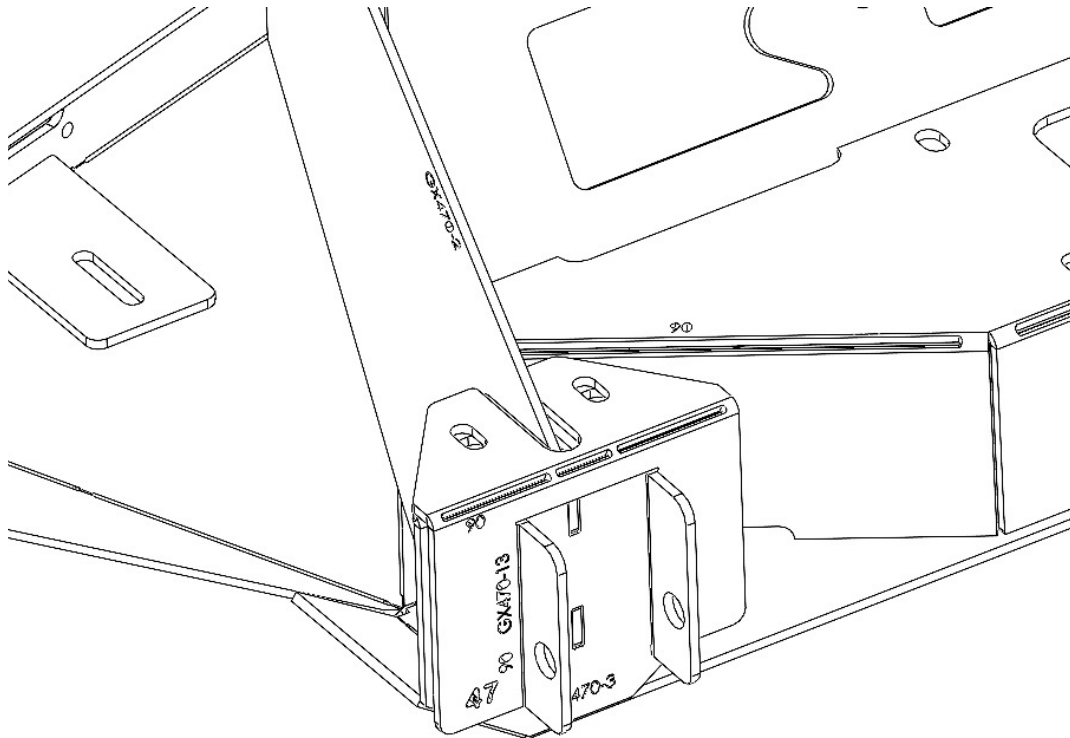

ASSEMBLY

- 12.** The final step to complete your bumper is inserting your D-ring shackles through the back of the bumper and squaring them up. Once the D-rings are square on each side, tack them to the bumper before fully welding them down to make you are happy with the look and fit.

