

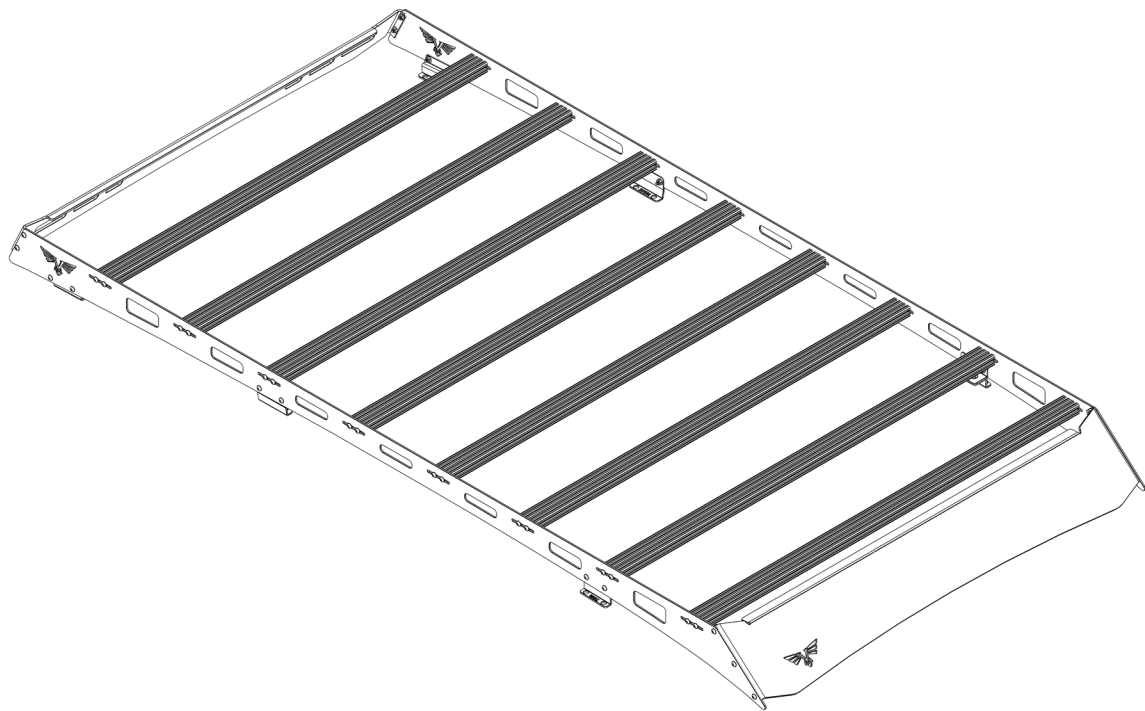

VICTORY 4X4

200 SERIES LAND CRUISER ROOF RACK

INSTALL INSTRUCTIONS



Please read the mounting instructions below carefully before attempting to install.

Check out the install video on the product page for factory rack disassembly.

Thank you for purchasing from Victory 4x4! Checkout our website, victory4x4.com for other great off-road products. Be sure to rate and review our product online. If you have any questions or are missing parts, please don't hesitate to call us at 269-459-8447!

INCLUDED HARDWARE

54x

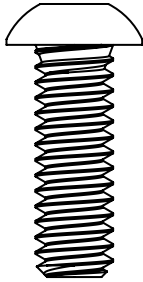

1/4"-20 X 3/4"
Button Head

4x

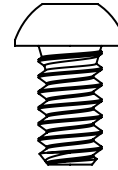

1/4"-20 X 3/8"
Button Head
Included with light
bar cutout option.

22x

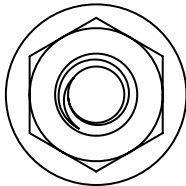

1/4"-20
Serr. Flange Nut

4x

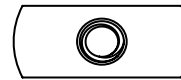

1/4"-20
T-Nut
Included with light
bar cutout option.

54x

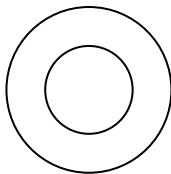

1/4" ID
Washer

12x

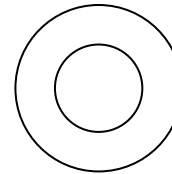

M8
Washer

12x

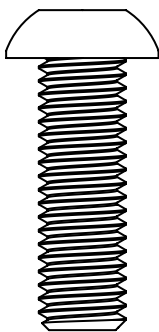

25mm M8
Button Head

4x

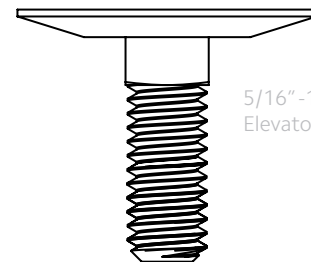

5/16"-18 X 1"
Elevator Bolt

4x

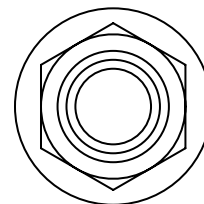

5/16"
Flanged Nylock Nut

INCLUDED PARTS

2x

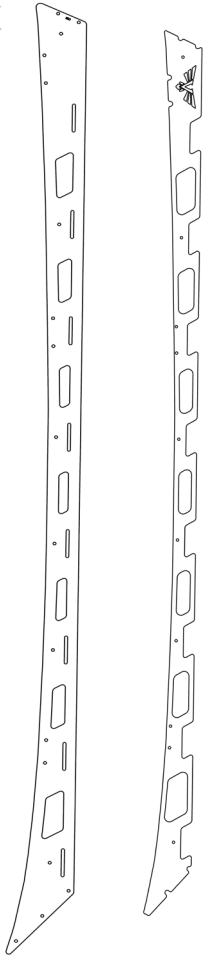

8x



1x

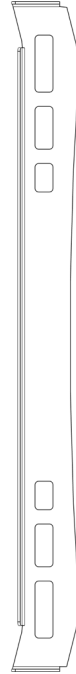

1x

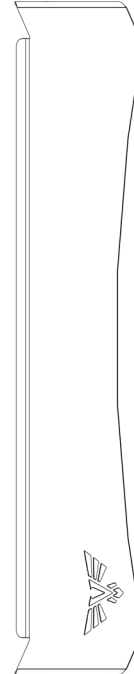

1x

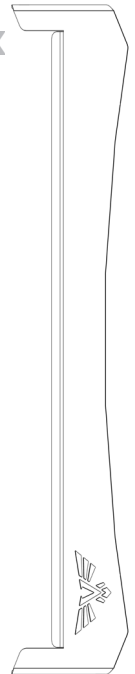

Or

1L/1R

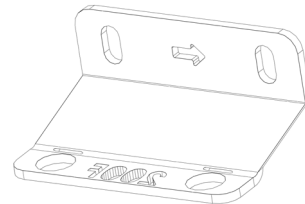

1L/1R

Included with light bar cutout option.

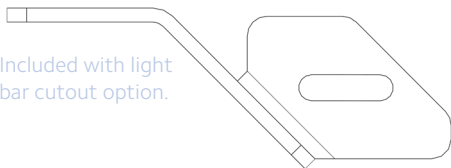

2x

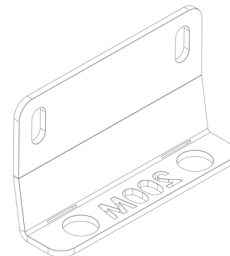

2x

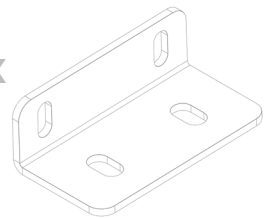

1L/1R

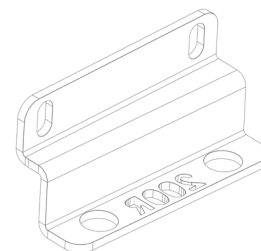

ASSEMBLY

NOTE: 2016+ LX570 models will require dropping the headliner and installing 8 roof rack mounting brackets (Toyota part# 63187-60040) before installing this rack.

- 1** Assemble the rack on the ground. Start by mounting the crossbars between the 2 side rails. For this, use the 1/4"-20 X 3/4" button head bolts and the 1/4" ID washers (2 per bar per side). Make sure the machined slot in the rail of the crossbar is facing up, so that you can easily add t-nuts to mount your gear.

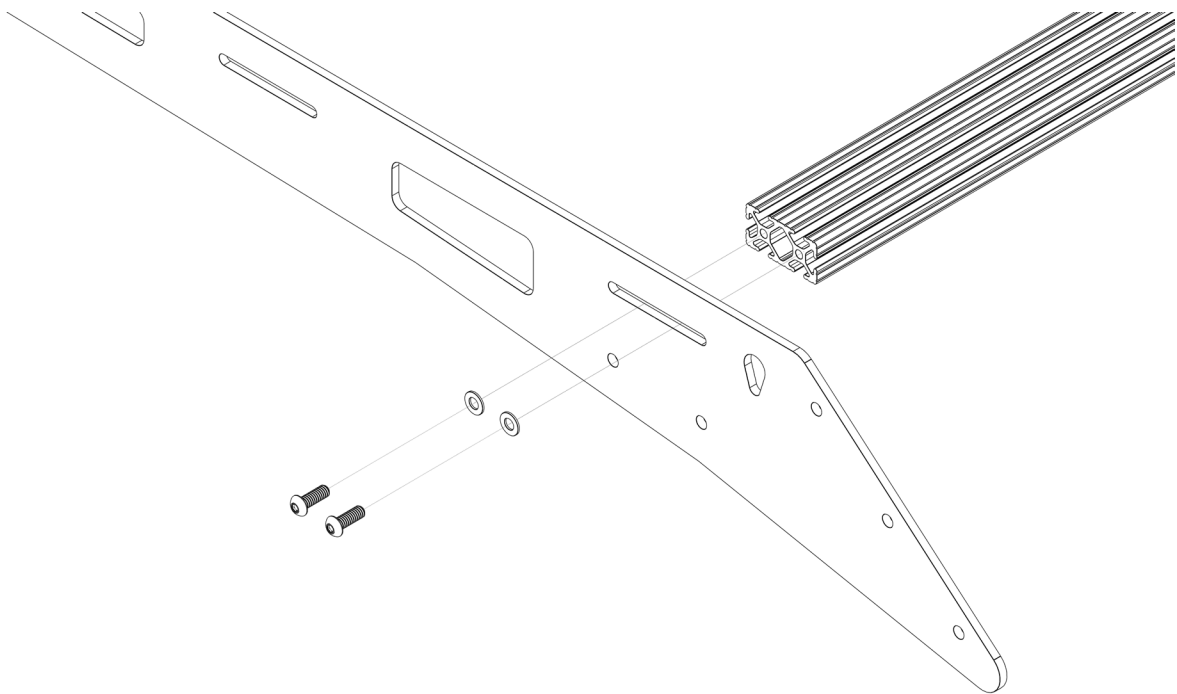

ASSEMBLY

- 2** Next, mount the strip of trim to the bottom edge of the front fairing. Start just to the outside of the peak of the bottom edge and continue until it reaches the equivalent point on the other side of the fairing. Cut off any extra. Then, cut the extra in half and mount the 2 pieces onto the bottom edge of the rear fairing wherever it contacts the roof of the vehicle.

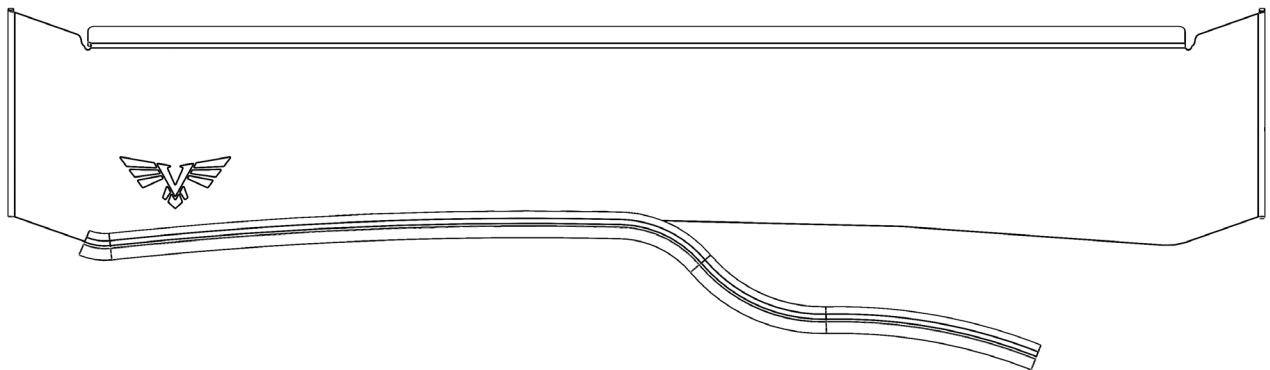

ASSEMBLY

- 3** Next, mount the front and rear fairings. To do this, use the 1/4"-20 X 3/4" button head bolts, 1/4" ID washers, and 1/4"-20 serrated flange nuts. The front fairing will need three of each per side and the rear fairing will need two of each per side. When mounting the front fairing, adjust it all the way up to avoid contact with the roof and leave the bolts loose enough to be able to make adjustments once it is on the roof of the vehicle.

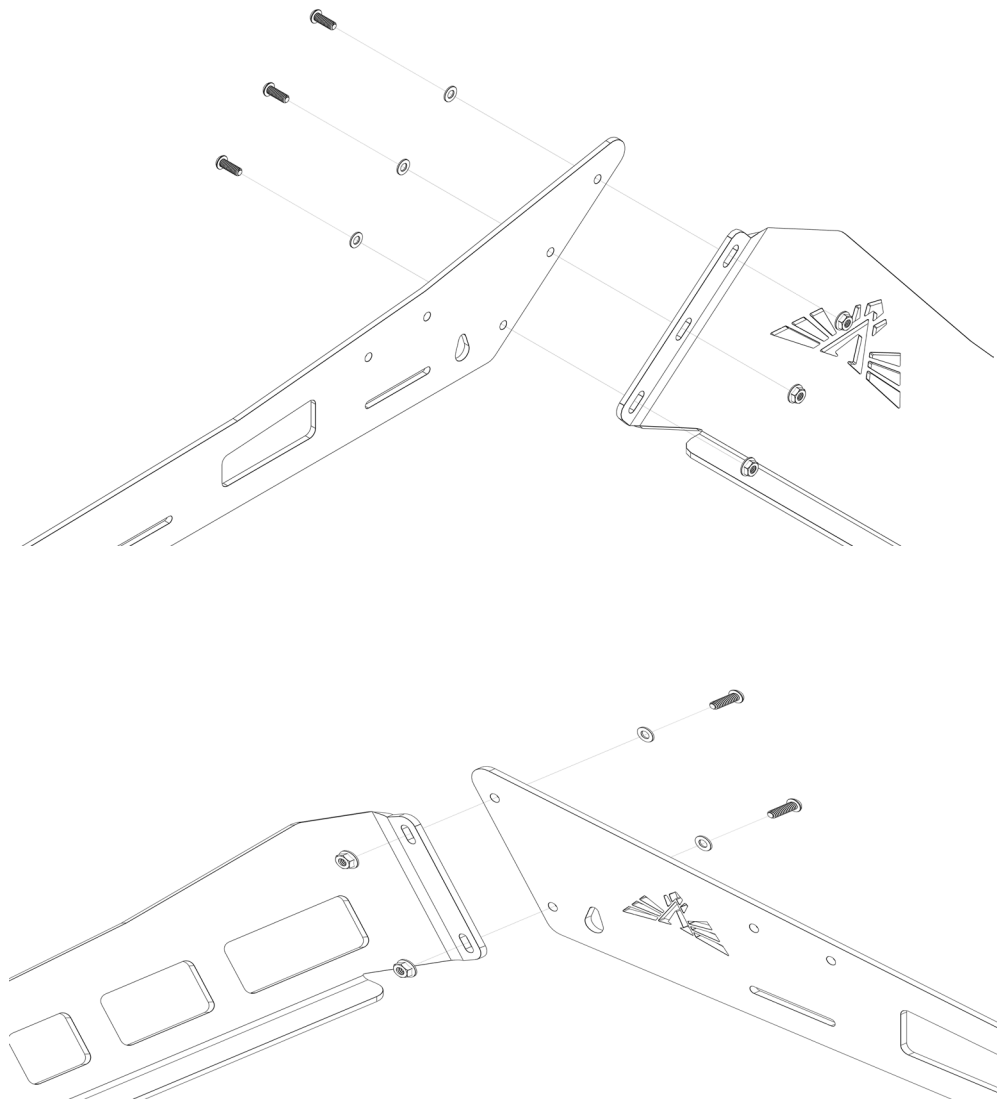

ASSEMBLY

- 4** Next, assemble the two halves of the front mounts. The side of the unlabeled bracket with the wider slots sits flat against the top of the of the brackets labeled with an F. It should be oriented so that the side with the smaller slots is above the flange with the letters cut out and pointing up. Then, insert the 5/16"-18 X 1" elevator bolt through the square hole, making sure that the square neck of the bolt sits inside the hole and fasten them using the 5/16"-18 nylock nuts. Leave this loose for now so you can make adjustments later.

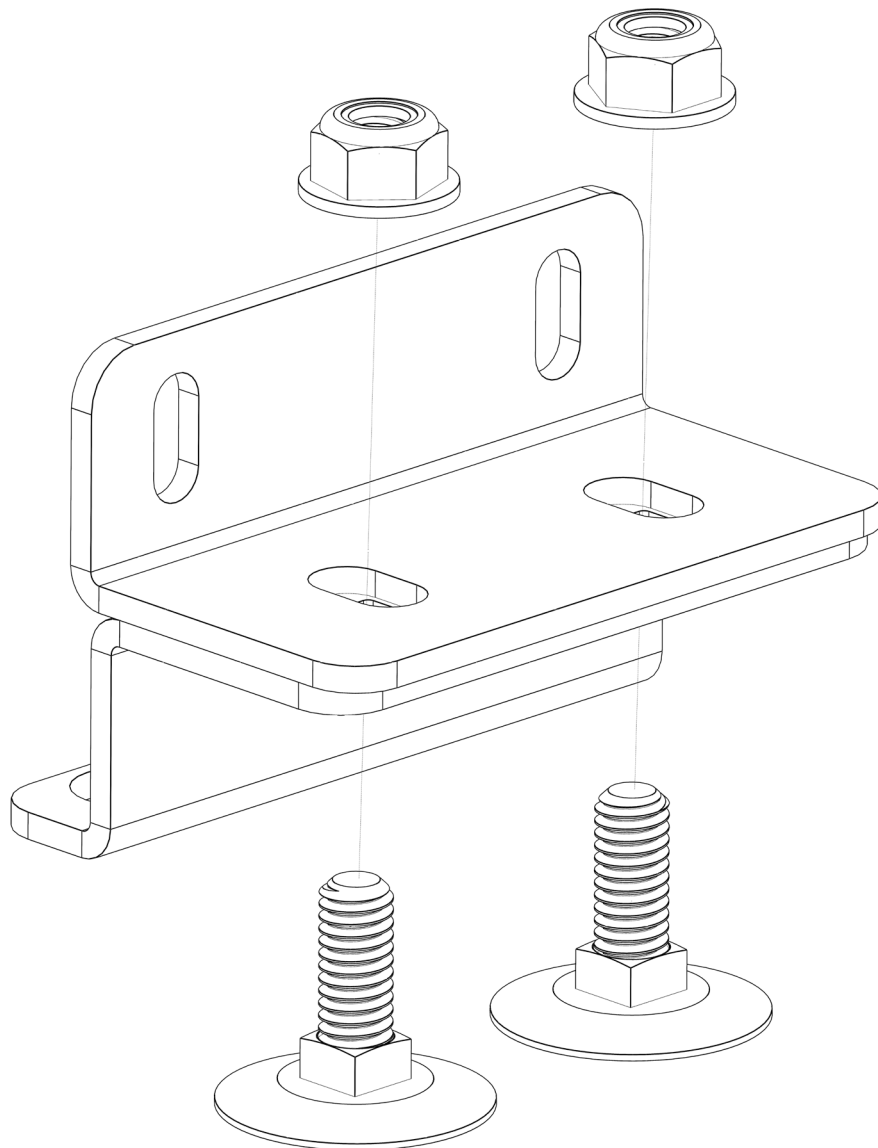

ASSEMBLY

- 5** Next, attach the mounts to inside of the rack using the 1/4"-20 X 3/4" button head bolts, 1/4" ID washers, and 1/4"-20 serrated flange nuts. The labeled flange on the mid and rear mounts should point towards the middle of the vehicle. On the front mounts, it should point towards the outside. The front and mid mounts are symmetrical and can go on either side. The rear mounts have an arrow on them that should be pointing towards the front of the vehicle.

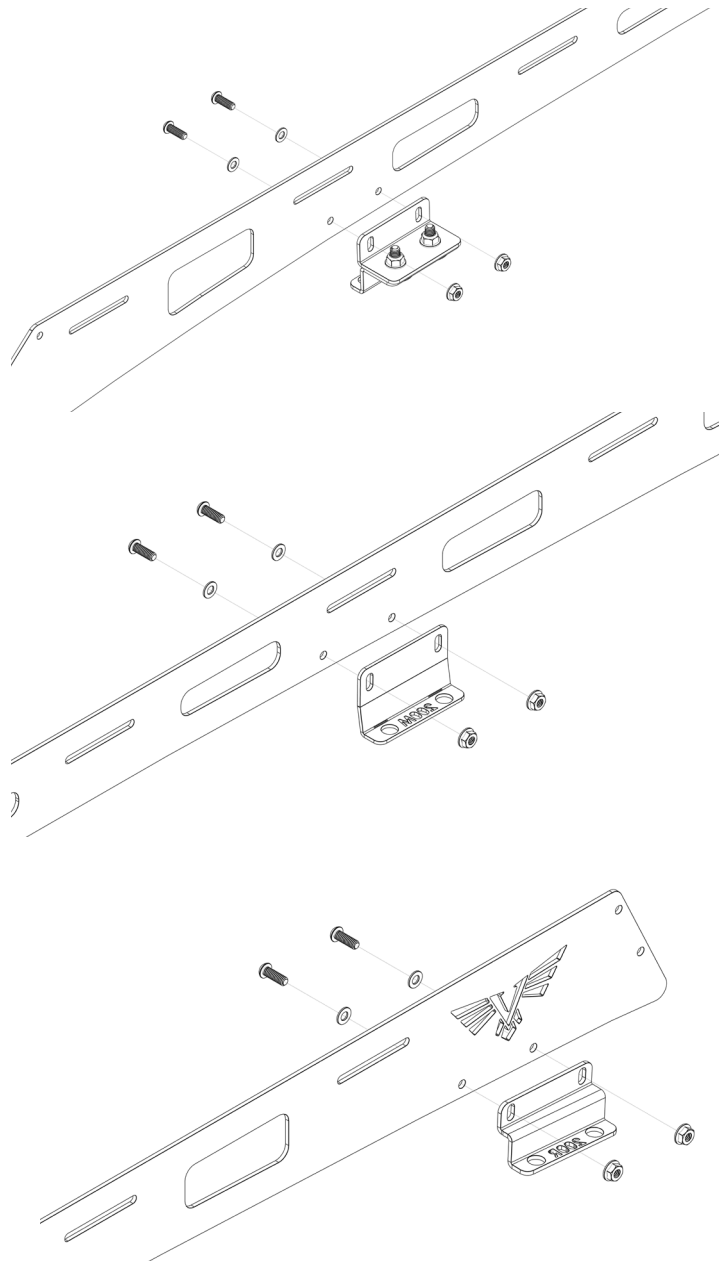

ASSEMBLY

- 6 Next, apply RTV around the mounting holes on the roof of the vehicle and set the assembled rack into place. Try to get it as close to the correct position as possible so that you don't accidentally spread the RTV while trying to sliding the rack into position. Then, cover and fill the top of the mounting holes with more RTV so that the bolts will have to pass through it when tightening the mount in to place. Next, tighten it fully into place with the M8 bolts and M8 washers.

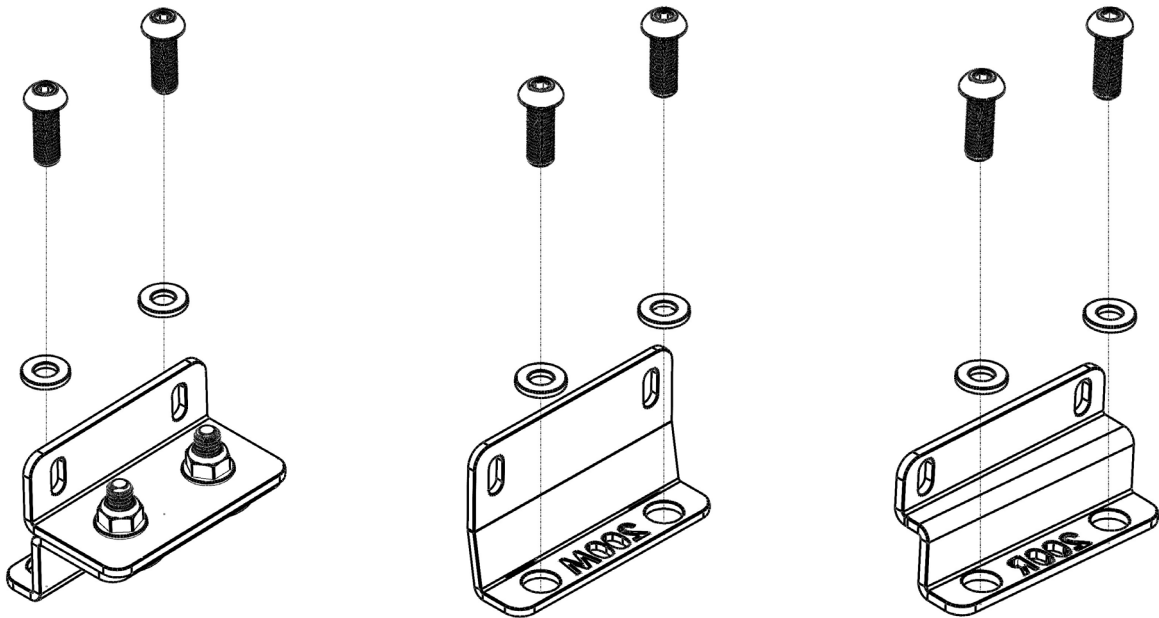

ASSEMBLY

- 7** With everything in place, make whatever adjustments that are necessary in order to get an even gap between the bottom edge of the rack and the roof, all the way down the length of the vehicle and then tighten it into place. Tighten the mounts to the vehicle first, then tighten the mid and rear mounts to the rack. Then, make sure the top part of the front mount is flat against the rail and tighten the elevator bolts, followed by the bolts into the side rail.
- 8** Finally, push the front and rear fairing down tight to the roof of the vehicle and tighten everything fully into place. We recommend applying clear 3M paint protection film to the roof of the vehicle anywhere the edge trim/ fairings make contact with the roof. This will protect the paint from dirt/ debris over time.

40" LIGHT BAR ASSEMBLY

- 1** Slide 2 t-nuts into each of the channels on the top side of the front-most crossbar using the slots. Then, place each light bar mount over one pair of t-nuts and loosely bolt it in place using the 1/4"-20 X 3/8" button heads.

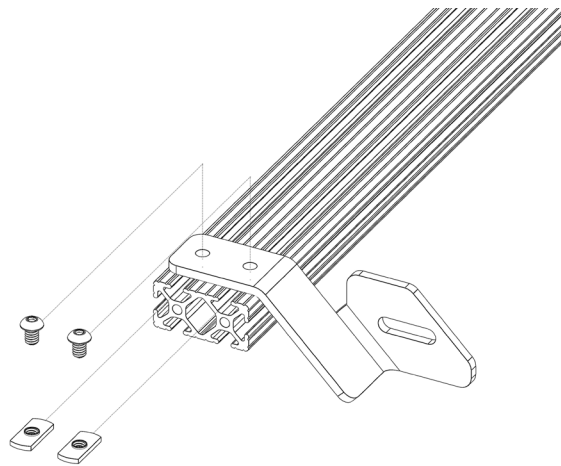

- 2** Next, place your light bar between the mounts and mount it in the slots using the hardware provided with the light bar. After that is firmly in position, make any adjustments to the positioning necessary to center the light bar on the rack. Depending on the rack and light bar, you may need to adjust the position of the cross bar in its slot as well.

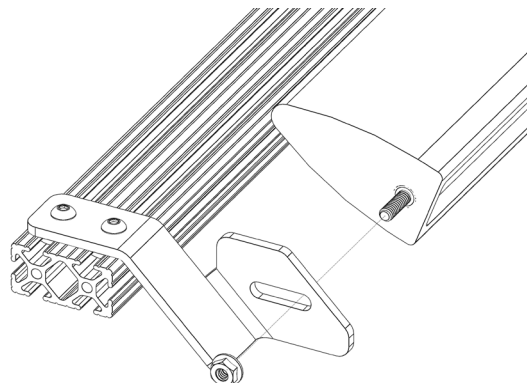

DIMENSIONS

