



VICTORY4X4

3RD GEN 4RUNNER

DIY FRONT BUMPER

INSTALL INSTRUCTIONS

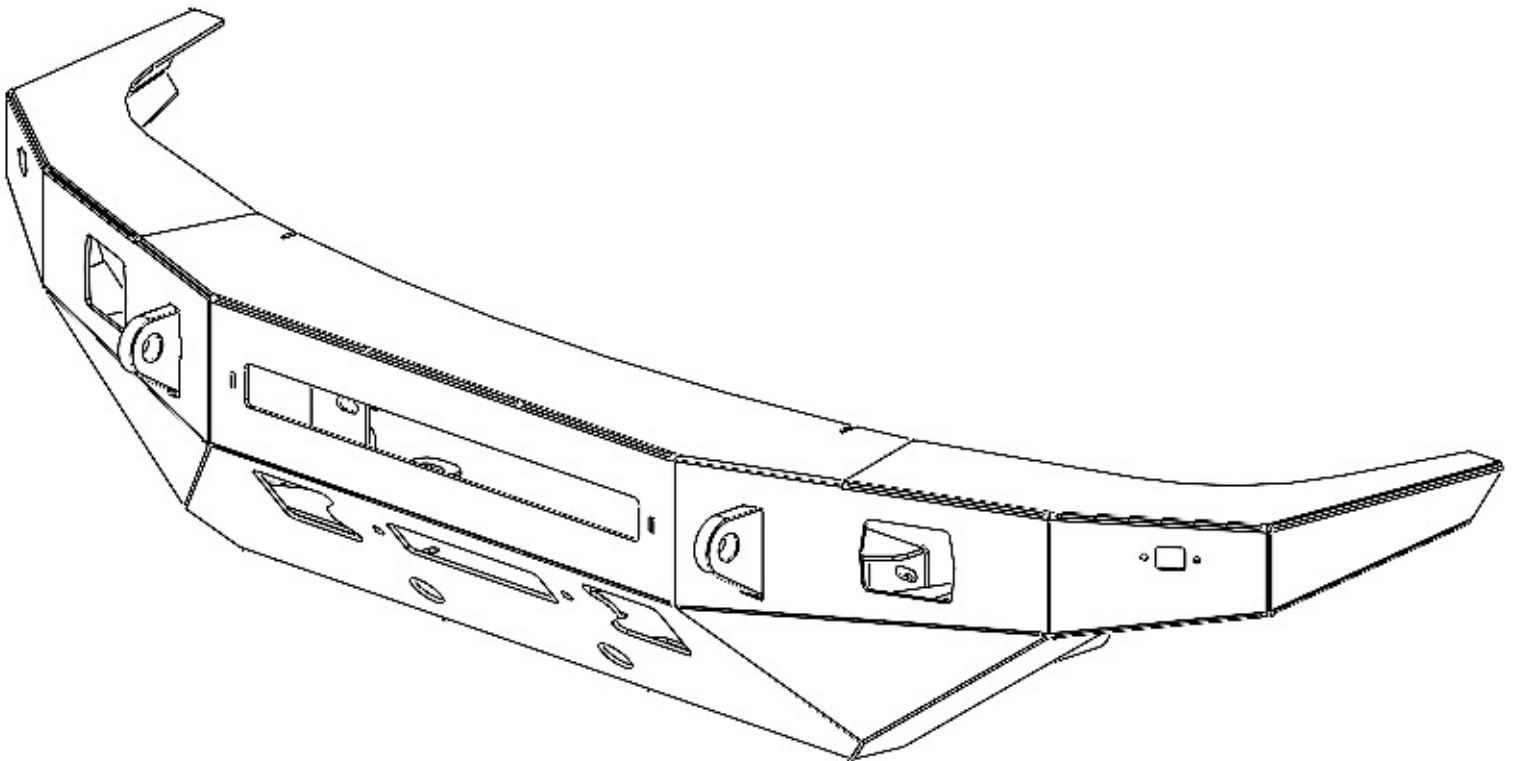

Please read the mounting instructions below carefully before attempting to install.

Be sure to check out the install video on the product page, if available.

Thank you for purchasing from Victory 4x4! Checkout our website, victory4x4.com for other great off-road products. Be sure to rate and review our product online. If you have any questions or are missing parts, please don't hesitate to call us at 269-459-8447!

INCLUDED HARDWARE

INCLUDED BOLT PACK(S) 046-0184

071-0039

Note: Some Victory 4x4/JCR Offroad/SquatchProof products share hardware kits. Any extra hardware you may receive that is not listed below can be repurposed or discarded.

4x

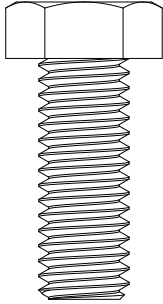

7/16"-14 x 1-1/2" Hex

4x

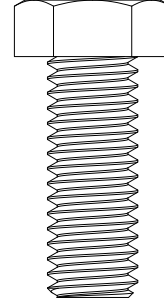

7/16"-14 x 1" Hex

8x

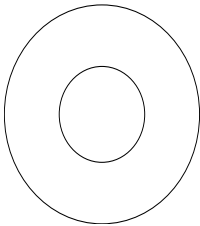

3/8 Uss Flat Washer Znc

8x

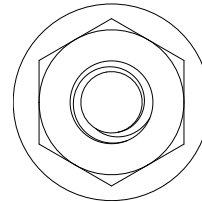

7/16"-14 Flange Nut

2x

2-3/4" x 1" Amber LED
Marker Light

4x

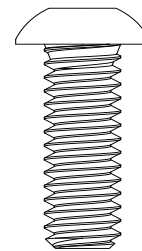

8-32 x 1-1/2" Long
Button Heads

4x

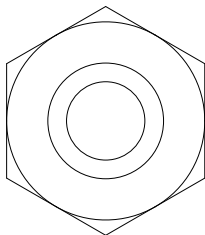

8-32 Hex Nylon
Locknut

4x



3/8" OD x 3/8" Long
Nylon Spacer

INCLUDED PARTS

1x #1 Center Section

2x #2 Wings

2x #3 Inside Wing Pieces

2x #4 Upright Supports

2x #5 Frame Mounts

1x #6 Winch Tray

2x #7 Cube Light Mounts

2x #8 Frame Bracket 1

2x #9 Frame Bracket 2

2x #10 Frame Tie-Ins

2x Lightbar Tabs

2x Shackle Tabs

ASSEMBLY

1. Before you start, **note that each of the bend angles are etched on the part along the slit lines.**

Start by bending all of your parts on the slit lines according to the angles called out. Below you will see each part and how they should look after they are bent. Note that there will be (2) part 2s and (2) part 10s that are lefts and rights, and will need to be mirror images of one another once bent.

1

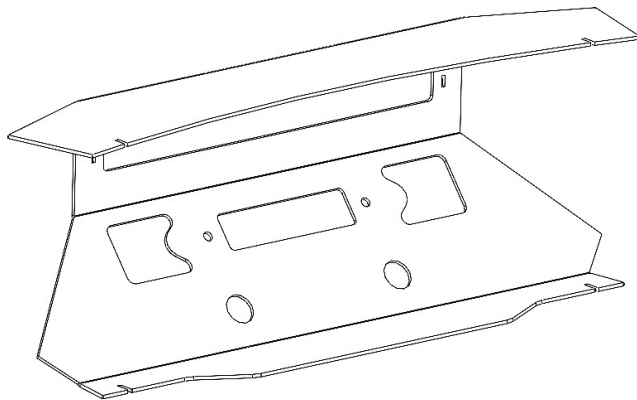

(L&R) 2

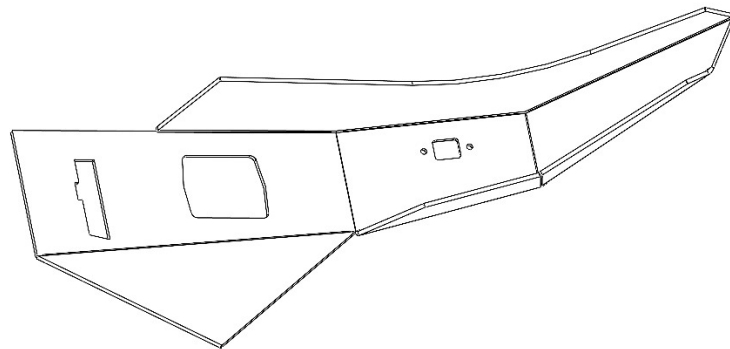

(2x) 5

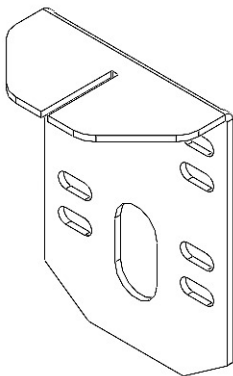

6

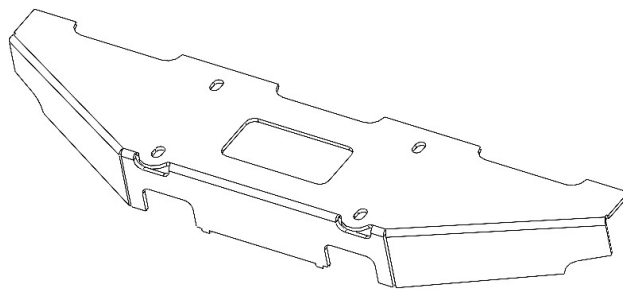

(2x) 8

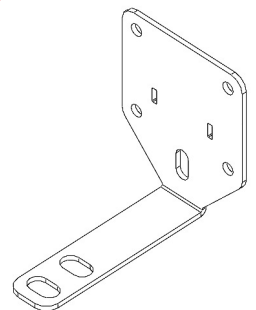

(2x) 9

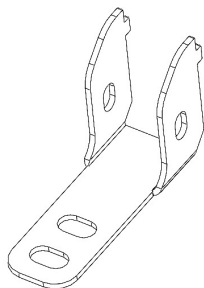

(L&R) 10

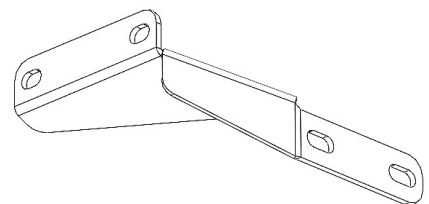

ASSEMBLY

2. Once all of your parts are bent to the correct angles, tack weld and assemble parts 1,4,5 & 6 using the tabs and making sure everything is square to one another. See reference picture below for an idea of what it should look like. You will also need to make sure to tack weld the frame mounts together before you can install the center section onto the truck. Also if you have a 99-02 model, you will need to trim the frame horns to accommodate the mounts. If you need additional info on trimming the frame horns, check out our Front Strike install video (at about the 3:30 mark) on our website for more details and a better visual.

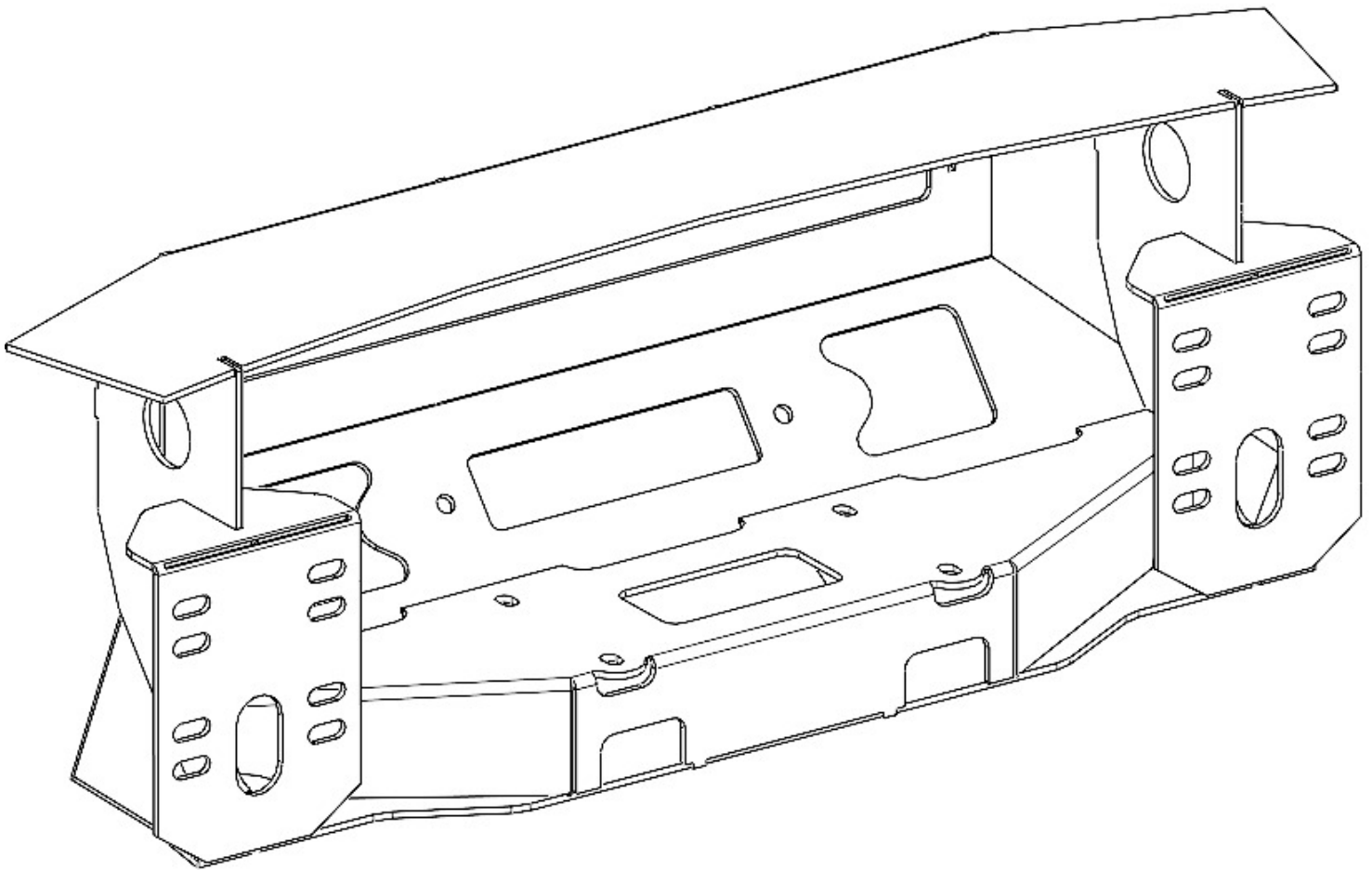

ASSEMBLY

3. Before the bumper can go onto the truck, you must loosely bolt the frame mounts and tie-in brackets to the truck so the center section can go on. As shown in the orientation below.

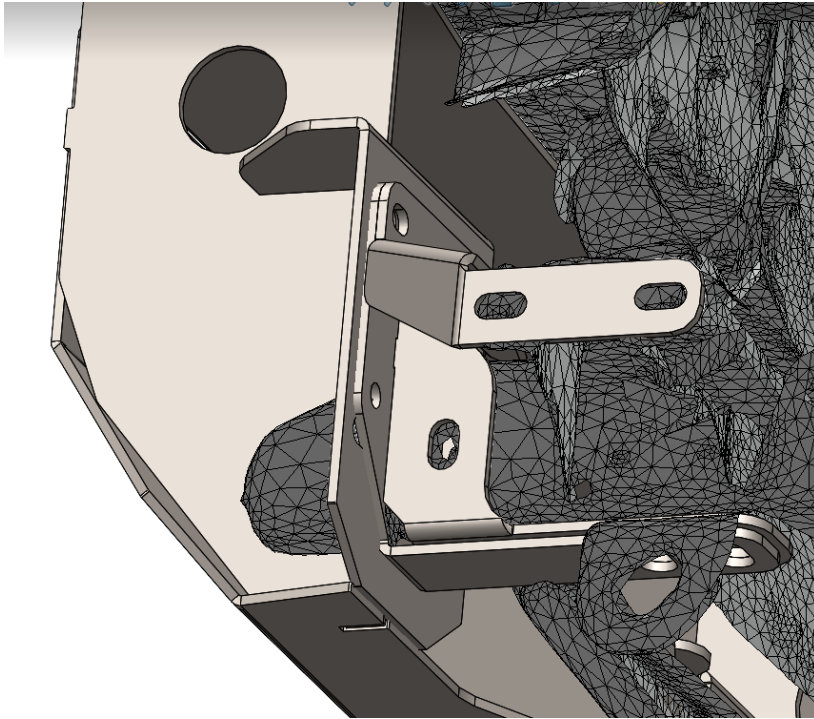

4. Once the mounts are in place, and before tacking the wings on, take the center section and bolt it to the frame mounts already on the truck. Once in place, mark and drill $9/16$ " holes through the frame on each side, using the holes on the side of the tie in brackets as a guide. You will need to source the (2) $1/2$ " x $3-1/2$ " bolts and nuts to secure the brackets.

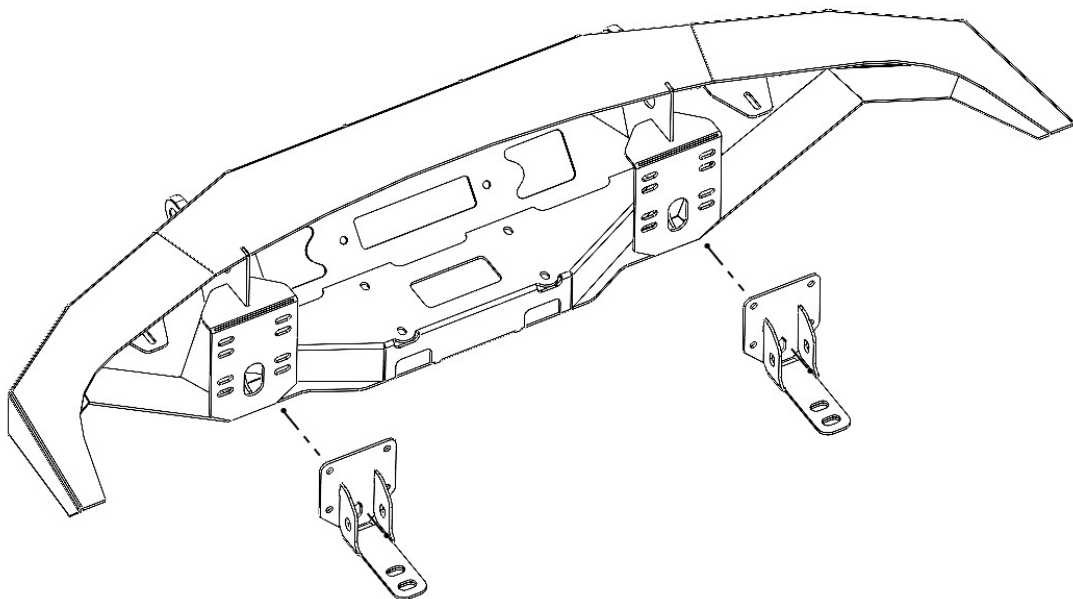

ASSEMBLY

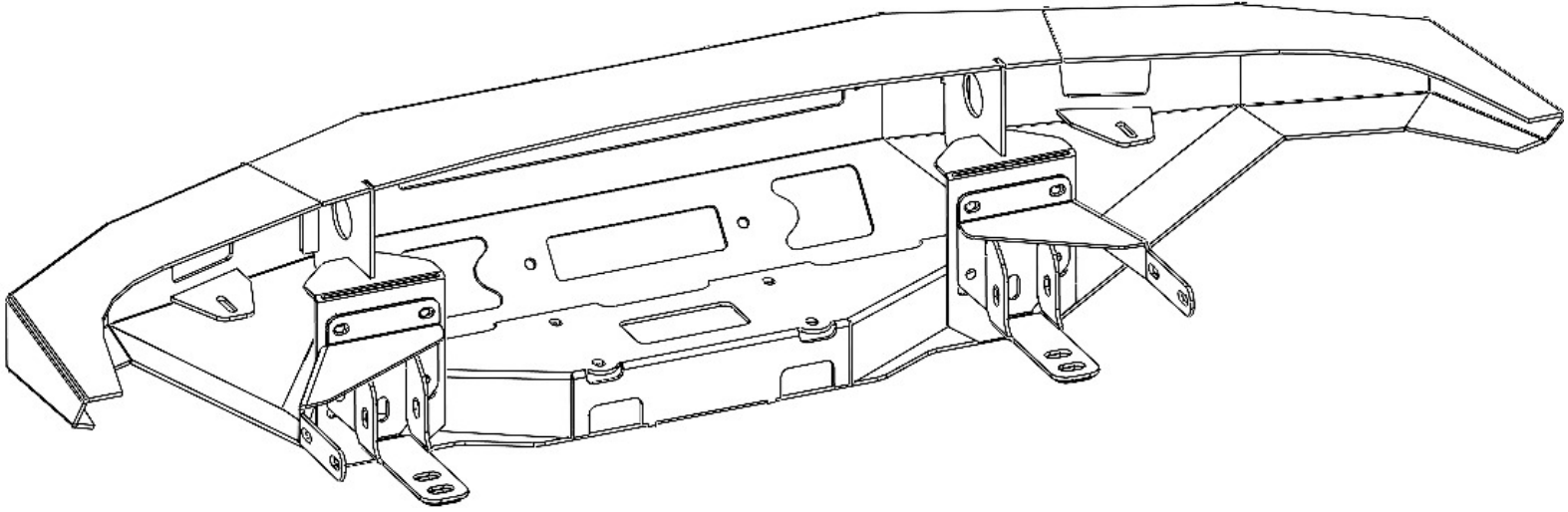

- 5.** Once your holes are drilled, make sure you have all of your hardware started and snug in the bumper before moving onto the next step to tack welding the wings on.

ASSEMBLY

- Using the headlights, grill and fenders as a reference, tack on both sides for part 2 on, working from the center out. You're looking for a uniform gap of $3/8$ " and $5/8$ " between each piece and the body. See reference pictures below of an exploded view for added help.

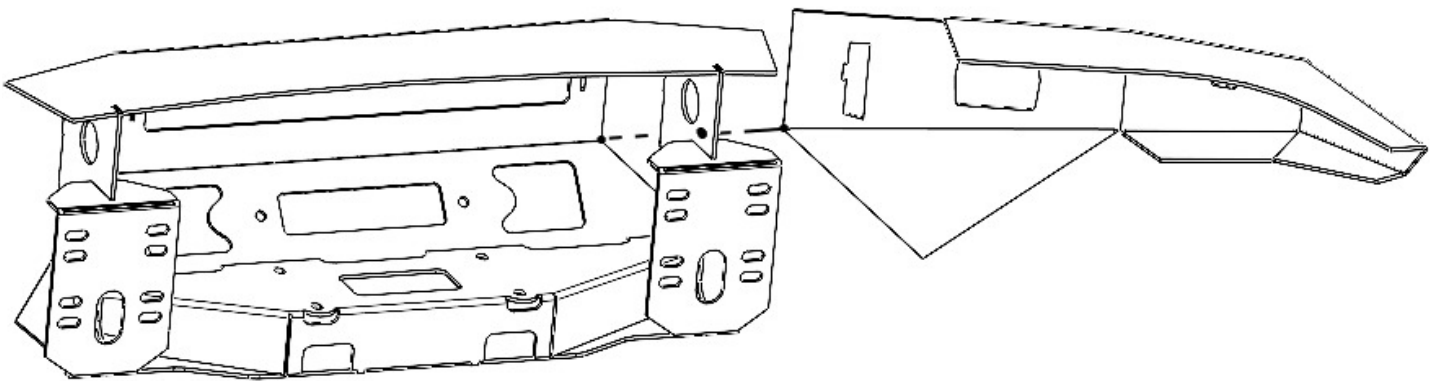

How it should look after both part 2's are tacked onto the shell.

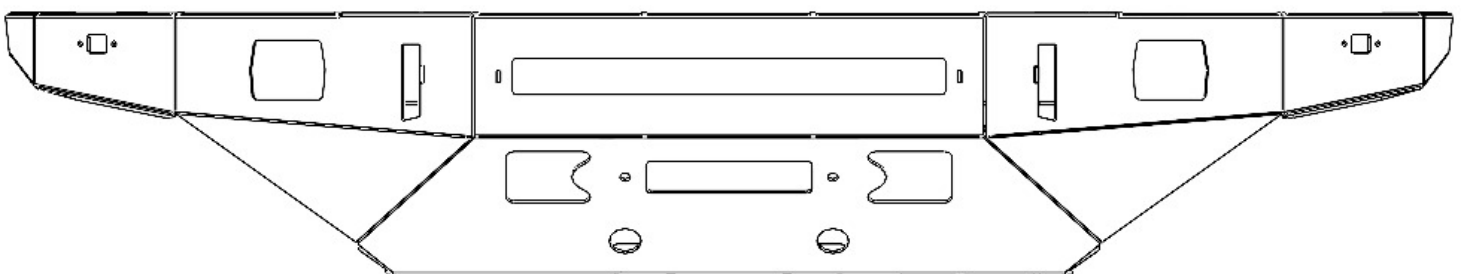

ASSEMBLY

7. Once you have the wings tacked on to the shell, the remaining wing pieces for each side (part 3) and tack them to the other wing piece, as shown in the orientation below.

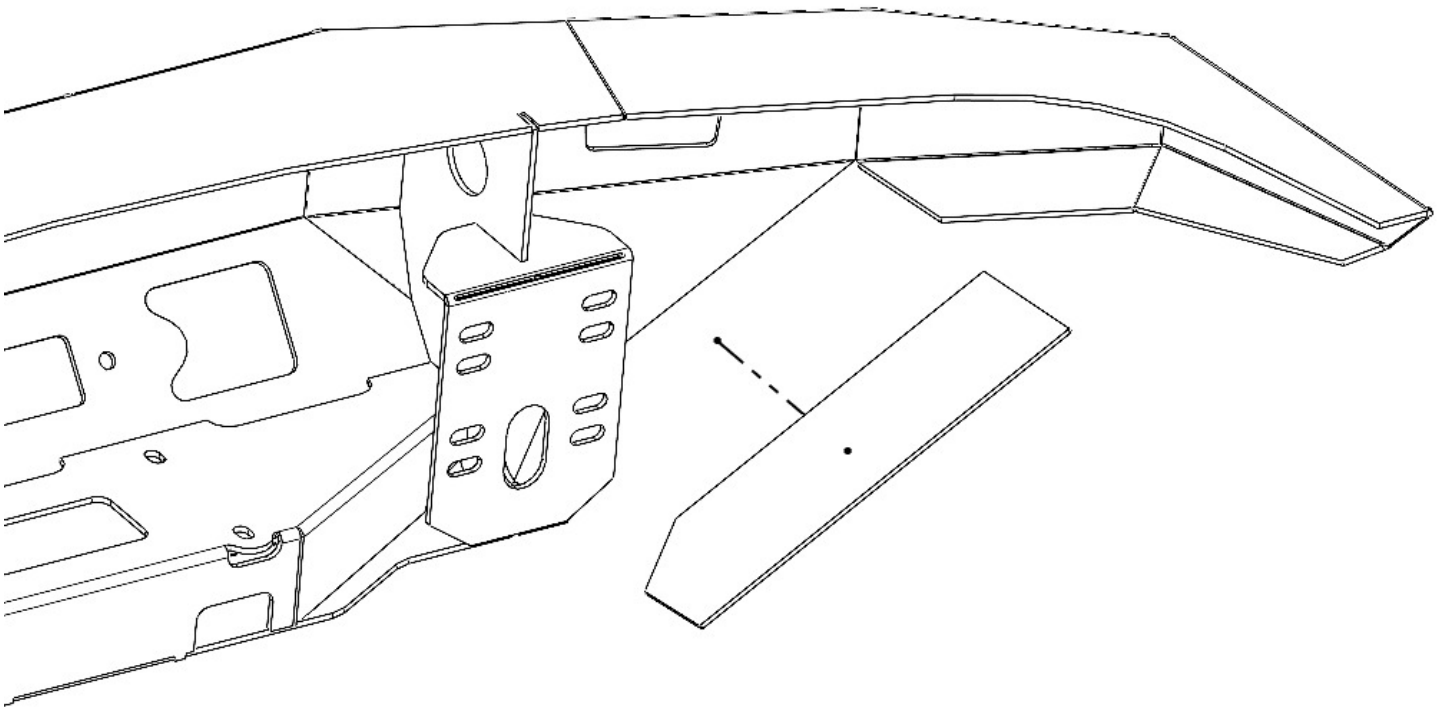

How it should look after both part 3's are tacked onto the wings.

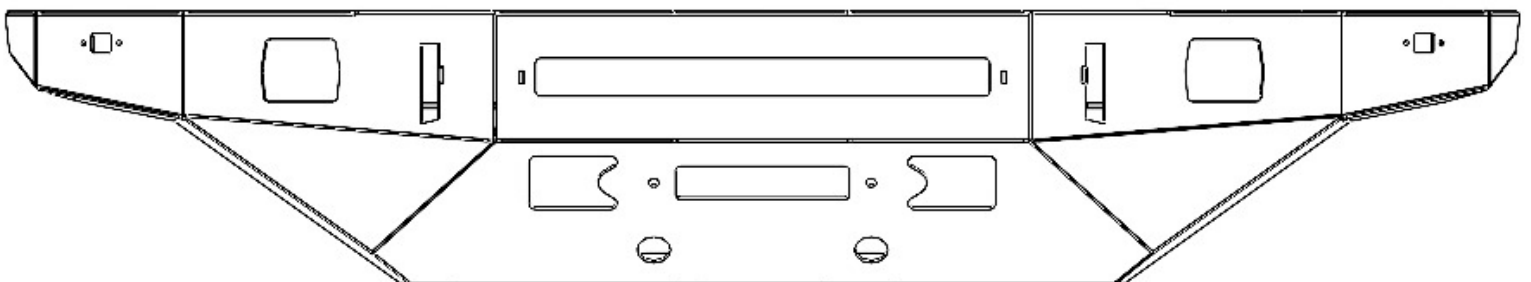

ASSEMBLY

8. Now that the bumper is fully tacked together on the truck, it is time to fully weld the seams. Keep in mind, with all of the heat produced by fully welding this bumper, you may experience some deformation or warping when welding. To avoid this, you may choose to do some of the welding with the bumper still mounted to the vehicle, to ensure it holds its desired shape. If you do remove the bumper to weld it fully, we recommend jumping around to different locations to avoid concentrating heat in one area. Clamping a rigid straight edge to the top of the wings can help prevent warping as well.
9. After the whole bumper has been fully welded together, using the cube lights of your choosing to set the height of your mounts, take the mounts (part 7) and weld them centered under the cube light cutouts on each side of the bumper, as shown below.

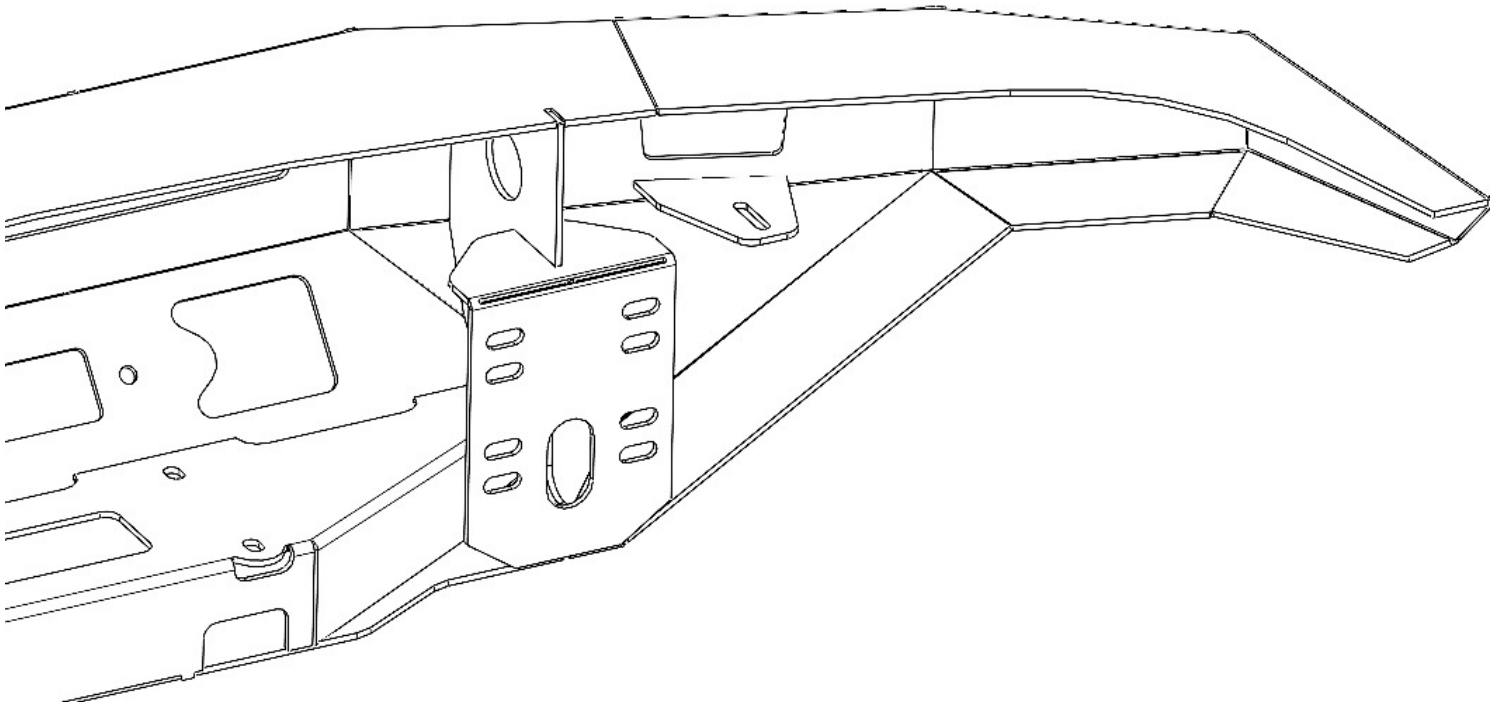

ASSEMBLY

- 10.** If you plan on running a light bar in your bumper, you will need to cut out rest of the light bar opening. Then you will take the lightbar of your choosing, and loosely assemble the tabs (part 8) to the light. Center the lightbar in the cutout and tack weld the tabs. Remove the light bar before fully welding the tabs into place. If you don't plan on running a light bar, you can weld and grind the cutout closed if you choose. This is also a good time to take the provided LED amber marker lights and bolt them into the bumper on each side, and wire them by tying them into the factory turn signals. Reference picture below of where to bolt them on the inside of the bumper.

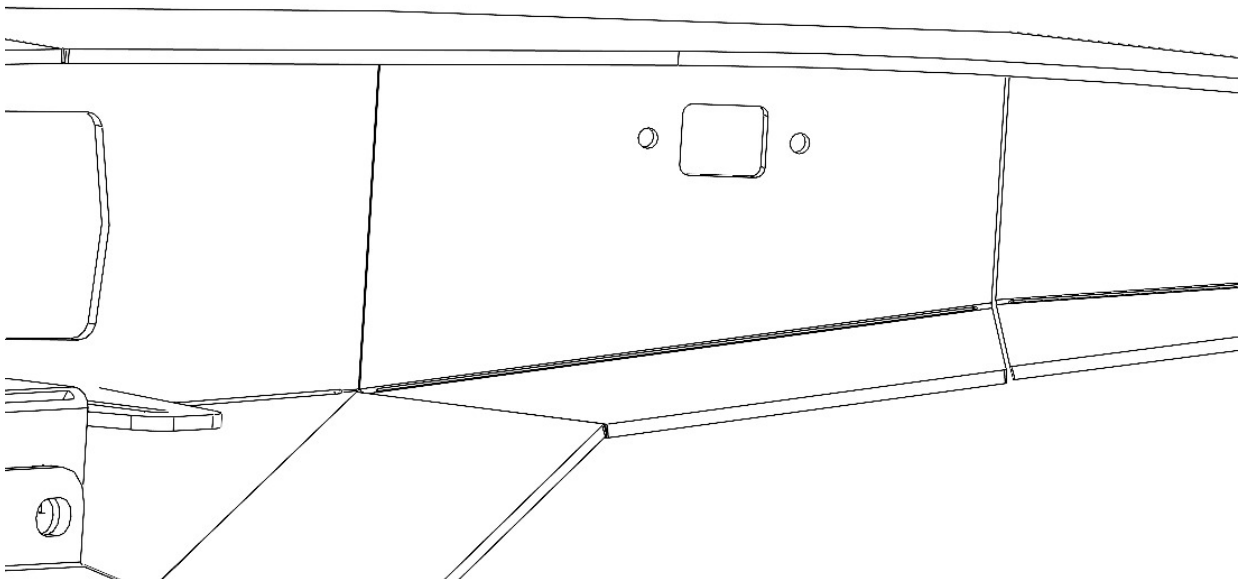
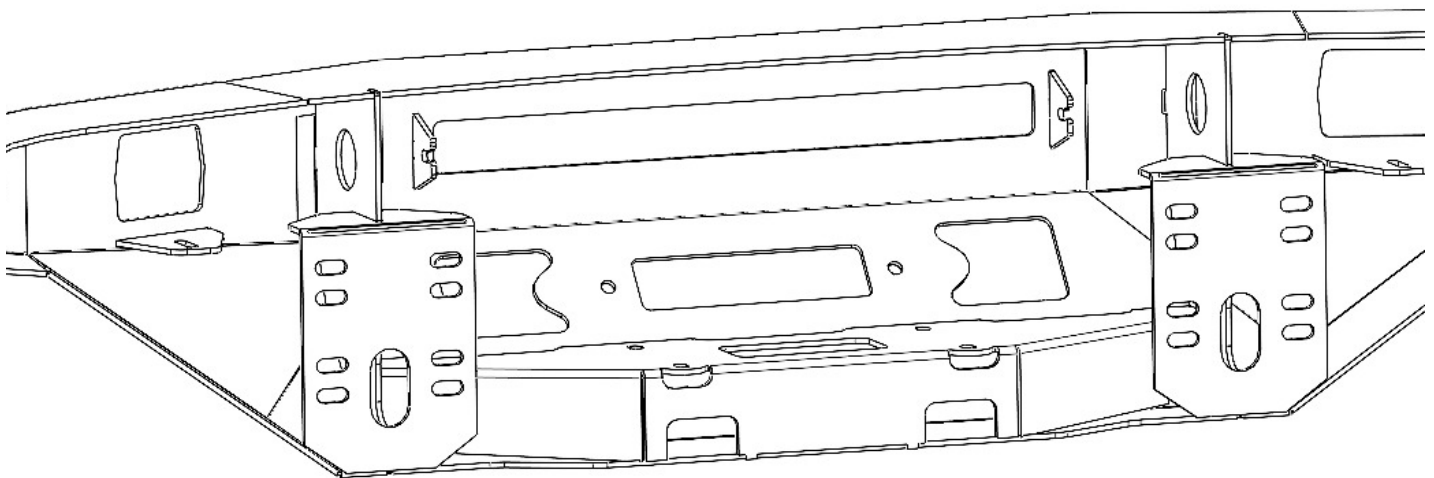

ASSEMBLY

- 11.** The final step to complete your bumper is inserting your shackle tabs through the back of the bumper and squaring them up. Once the shackle tabs are square on each side, tack them to the bumper before fully welding them down to make you are happy with the look and fit.
- 12.** Your DIY front is now complete, you are free to add a winch and/or wire any lights you may have added. Be sure to check out our website at Victory4x4.com for even more 4Runner products.

